



**INDIAN INSTITUTE OF TECHNOLOGY, KANPUR**  
**GT ROAD, KALYANPUR, KANPUR – 208016**  
**UTTAR PRADESH, INDIA**

**TENDER REFERENCE NO.: IITK/SEE/SCU/SOLAR/2024/01**

**BID SUBMISSION END DATE – 09/12/2024**

**TENDER DOCUMENT**

For

***“Supplying, Installation, Commissioning, and Testing of grid-connected 100 kW solar PV plant at The Sindhu Central University (SCU) - Khalatse, Ladakh, India.*”**

Location Coordinates: 34.3192846, 76.8918722

Address: SINDHU CENTRAL UNIVERSITY transit campus, near Govt. Degree college, Khalatse,  
Leh-Kargil Highway, LEH, Ladakh-194106

## **INDEX**

**Name of Work:** ***“Supplying, Installation, Commissioning, and Testing of grid-connected 100 kW solar PV plant at The Sindhu Central University (SCU) - Khalatse, Ladakh, India.***

<b>Sl. No.</b>	<b>Description</b>	<b>Page</b>
1.	E-TENDER NOTICE	3
2.	INFORMATION OF E-TENDERING FOR CONTRACTORS	4
3.	BID DOCUMENT	5
4.	INSTRUCTIONS FOR ONLINE BID SUBMISSION	6
5.	INSTRUCTION FOR E-PROCUREMENT	9
6.	COMMERCIAL TERMS AND CONDITIONS	15
7.	TENDER DOCUMENT	23
8.	TECHNICAL SPECIFICATION (Section 1-3)	25
9.	TECHNICAL SPECIFICATIONS OF MAJOR EQUIPMENT	35
10.	TENDER DRAWINGS, PLAN, AND STANDARD SLD	38
11.	DEFECT LIABILITY PERIOD (DLP)	39
12.	LIST OF APPROVED MAKES	42
13.	REQUIREMENT OF TECHNICAL REPRESENTATIVE	44
14.	QUALITY ASSURANCE OF THE WORK	45
15.	PAYMENT REGULATION	47
16.	SPECIAL CONDITION FOR SAFETY AT THE WORK SITE	49
17.	APPENDIX	50-54

Member1

Member2

Member3

**INDIAN INSTITUTE OF TECHNOLOGY KANPUR**  
**Department of Sustainable Energy Engineering**  
**E-TENDER NOTICE**

NIT No. IITK/SEE/SCU/SOLAR/2024/01

Dated: 09/12/2024

Prof. Rajeev Jindal, and Prof. Debopam Das of SEE-Department, IIT Kanpur on behalf of the Board of Governors of IIT Kanpur invites online item rate tenders from eligible specialized agencies for the following work:-

Sl. No	Name of work and location	Estimated cost put to tender (In Rs.) (including all taxes & GST)	Earnings Money (In Rs.)	Period of Completion (in Month)	Last date & time of submission of tender	Period during which EMD, Cost of Tender Document, e-Tender Processing Fee and other Documents shall be submitted	Time & date of opening of tender
1	<b><i>“Supplying, Installation, Commissioning, and Testing of grid-connected 100 kW solar PV plant at The Sindhu Central University (SCU) - Khalatse, Ladakh, India.</i>”</b>		1 Lakhs	6 Months From the date of PO	<b>09/12/2024</b> (16.00hrs)	After last date and time of submission of tender and up to <b>09/12/2024</b> (16.00 hrs)	<b>10/12/2024</b> (16.00 hrs)

The E-tender documents is available at <http://eprocure.gov.in/eprocure/app>

**Principal Investigator**

Copy to:

1. Institute website: [www.iitk.ac.in/iwd/tenderhall.htm](http://www.iitk.ac.in/iwd/tenderhall.htm)
2. Notice Board

## Information of e-Tendering for Contractors

1. The intending tenderer must read the terms and conditions of FORM-6 for e-Tendering carefully. He should only submit his tender if he considers himself eligible and he is in possession of all the documents required.
2. Information and Instructions for tenderer posted on website shall form part of tender document.
3. The tender document consisting of plans, specifications, the schedule of quantities of various types of items to be executed and the set of terms and conditions of the contract to be complied with and other necessary documents can be seen and downloaded from website <https://eprocure.gov.in/eprocure/app> or [www.iitk.ac.in](http://www.iitk.ac.in) free of cost.
4. But the tender can only be submitted after uploading the mandatory scanned documents as per list given below.
5. Those contractors not registered on the website mentioned above, are required to get registered beforehand. If needed they can be imparted training on online bidding process as per details available on the website.
6. The intending bidder must read the terms and conditions carefully. He should submit his bid only if he considers himself eligible and he is in possession of all the documents as required
7. The intending bidder must upload all the documents as detailed in this tender document.
8. Applicants are advised to keep visiting [www.iitk.ac.in/iwd/tenderhall.htm](http://www.iitk.ac.in/iwd/tenderhall.htm), <http://eprocure.gov.in/eprocure/app>, [www.tenderhome.com](http://www.tenderhome.com), and [www.eprocure.gov.in/cppp/latestactivetenders](http://www.eprocure.gov.in/cppp/latestactivetenders), from time to time (till the deadline for bid submission) for any updates in respect of the tender documents, if any. Failure to do so shall not absolve the applicant of his liabilities to submit the applications complete in all respect including updates thereof, if any. An incomplete application may be liable for rejection.
9. The EMD shall be prepared in favor of “**Registrar IIT Kanpur**” payable at **Kanpur** as detailed in the tender document. A part of EMD is acceptable in the form of bank guarantee as per the details in the tender document. This bank guarantee shall also be in favor of “**Registrar IIT Kanpur**”.
10. The defect liability period is 60 months from the date of handing over the completed building to the Principal Investigator. Other related details are elaborated in the tender document.
11. Site inspection / Pre-Bid meeting, if desired, by the intending bidders will be arranged on **Nov 22, 2024**, at **11:00 AM**. The intending bidders must reach the O/o the Principal Investigator, Department of Sustainable Energy Engineering, IIT Kanpur -208016. The construction site is inside the IIT Kanpur Campus. The intending bidders shall arrange for the conveyance themselves. Bidders are advised to send their queries/ doubts by email to the Principal Investigator on email id: [rajeevj@iitk.ac.in](mailto:rajeevj@iitk.ac.in), [kchandani@iitk.ac.in](mailto:kchandani@iitk.ac.in) at least one day prior to the pre-bid meeting. No further queries after the pre-bid meeting shall be entertained.
12. The indicative drawings and sample images are enclosed.

## **BID DOCUMENT**

The Indian Institute of Technology Kanpur (“IITK”) invites Bids (“Bids”) from eligible, qualified, and capable companies for the supply and delivery of **“Supplying, Installation, Commissioning, and Testing of grid-connected 100 kW solar PV plant at The Sindhu Central University (SCU) – Khalatse-194106, Ladakh, India..** according to the requirements as defined in the Tender document.

Notice Inviting Tender No.	<b>IITK/SEE/SCU/SOLAR/2024/01 DT: 09/12/2024</b>
Name of Work	<b><i>“Supplying, Installation, Commissioning, and Testing of grid-connected 100 kW solar PV plant at The Sindhu Central University (SCU) - Khalatse, Ladakh, India.</i></b>
Estimated Cost	—
Earnest Money	1,00,000/-
<b>Date of Publishing</b>	11/11/ 2024 (16.00 hrs)
Clarification Start Date and Time	11/11/ 2024 (16.00 hrs)
Clarification End Date and Time	09/12/ 2024 (16.00 hrs)
Queries (if any)	No queries will be entertained after clarification end date and time
<b>Bid Submission Start Date</b>	11/11/ 2024 (16.00 hrs)
Site inspection / Pre-Bid meeting Date & Time	22/11/2024 (11.00 hrs)
Last Date and time of uploading of Bids	09/12/ 2024 (16.00 hrs)
Last Date and time of <b>submitting</b> , EMD and other documents at IIT Kanpur (if any)	09/12/ 2024 (16.00 hrs)
Date and time of opening of Technical Bids	10/12/ 2024 (16.00 hrs)
Date and time of opening of Financial Bids	Will be separately notified for Technically shortlisted/qualified bidders

Interested parties may view and download the tender document containing the detailed terms & conditions from the website <http://eprocure.gov.in/eprocure/app>

**(The bids must be submitted online in electronic form on [www.eprocure.gov.in](http://www.eprocure.gov.in) only. No physical bids will be accepted.)**

## (Part-A)

### Instructions for Online Bid Submission

The bidders are required to submit soft copies of their bids electronically on the CPP Portal, using valid Digital Signature Certificates. The instructions given below are meant to assist the bidders in registering on the CPP Portal, prepare their bids in accordance with the requirements and submitting their bids online on the CPP Portal.

More information useful for submitting online bids on the CPP Portal may be obtained at: <https://eprocure.gov.in/eprocure/app>.

#### 1 REGISTRATION

- 1) Bidders are required to enroll on the e-Procurement module of the Central Public Procurement Portal (URL: <https://eprocure.gov.in/eprocure/app>) by clicking on the link “**Online bidder Enrollment**” on the CPP Portal which is free of charge.
- 2) As part of the enrolment process, the bidders will be required to choose a unique username and assign a password for their accounts.
- 3) Bidders are advised to register their valid email address and mobile numbers as part of the registration process. These would be used for any communication from the CPP Portal.
- 4) Upon enrolment, the bidders will be required to register their valid Digital Signature Certificate (Class III Certificates with signing key usage) issued by any Certifying Authority recognized by CCA India (e.g. Sify / nCode / eMudhra etc.), with their profile.
- 5) Only one valid DSC should be registered by a bidder. Please note that the bidders are responsible to ensure that they do not lend their DSC's to others which may lead to misuse.
- 6) Bidder then logs in to the site through the secured log-in by entering their user ID / password and the password of the DSC / e-Token.

#### 2 SEARCHING FOR TENDER DOCUMENTS

- 1) There are various search options built in the CPP Portal, to facilitate bidders to search active tenders by several parameters. These parameters could include Tender ID, Organization Name, Location, Date, Value, etc. There is also an option of advanced search for tenders, wherein the bidders may combine a number of search parameters such as Organization Name, Form of Contract, Location, Date, Other keywords etc. to search for a tender published on the CPP Portal.
- 2) Once the bidders have selected the tenders they are interested in, they may download the required documents / tender schedules. These tenders can be moved to the respective 'My Tenders' folder. This would enable the CPP Portal to intimate the bidders through SMS / e- mail in case there is any corrigendum issued to the tender document.
- 3) The bidder should make a note of the unique Tender ID assigned to each tender,

in case they want to obtain any clarification / help from the Helpdesk.

### 3 PREPARATION OF BIDS

- 1) Bidder should take into account any corrigendum published on the tender document before submitting their bids.
- 2) Please go through the tender advertisement and the tender document carefully to understand the documents required to be submitted as part of the bid. Please note the number of covers in which the bid documents have to be submitted, the number of documents - including the names and content of each of the document that need to be submitted. Any deviations from these may lead to rejection of the bid.
- 3) Bidder, in advance, should get ready the bid documents to be submitted as indicated in the tender document / schedule and generally, they can be in PDF / XLS / RAR / DWF/JPG formats. Bid documents may be scanned with 100 dpi with black and white option which helps in reducing size of the scanned document.
- 4) To avoid the time and effort required in uploading the same set of standard documents which are required to be submitted as a part of every bid, a provision of uploading such standard documents (e.g. PAN card copy, annual reports, auditor certificates etc.) has been provided to the bidders. Bidders can use "My Space" or "Other Important Documents" area available to them to upload such documents. These documents may be directly submitted from the "My Space" area while submitting a bid and need not be uploaded again and again. This will lead to a reduction in the time required for bid submission process.

**Note:** *My Documents space is only a repository given to the Bidders to ease the uploading process. If Bidder has uploaded his Documents in My Documents space, this does not automatically ensure these Documents being part of Technical Bid.*

### 4 SUBMISSION OF BIDS

- 1) Bidder should log into the site well in advance for bid submission so that they can upload the bid in time i.e. on or before the bid submission time. Bidder will be responsible for any delay due to other issues.
- 2) The bidder has to digitally sign and upload the required bid documents one by one as indicated in the tender document.
- 3) Bidder has to select the payment option as "offline" to pay the tender fee / EMD as applicable and enter details of the instrument.
- 4) Bidder should prepare the EMD as per the instructions specified in the tender document. The original should be posted/couriered/given in person to the concerned official, latest by the last date of bid submission or as specified in the tender documents. The details of the DD/any other accepted instrument, physically sent, should tally with the details available in the scanned copy and the data entered during bid submission time. Otherwise, the uploaded bid will be rejected.
- 5) Bidders are requested to note that they should necessarily submit their financial bids in the format provided and no other format is acceptable. If the price bid has been given as a standard BoQ format with the tender document, then the same is to be downloaded and to be filled by all the bidders. Bidders are required to download

the BoQ file, open it and complete the white coloured (unprotected) cells with their respective financial quotes and other details (such as name of the bidder). No other cells should be changed. Once the details have been completed, the bidder should save it and submit it online, without changing the filename. If the BoQ file is found to be modified by the bidder, the bid will be rejected.

- 6) The server time (which is displayed on the bidders' dashboard) will be considered as the standard time for referencing the deadlines for submission of the bids by the bidders, opening of bids etc. The bidders should follow this time during bid submission.
- 7) All the documents being submitted by the bidders would be encrypted using PKI encryption techniques to ensure the secrecy of the data. The data entered cannot be viewed by unauthorized persons until the time of bid opening. The confidentiality of the bids is maintained using the secured Socket Layer 128-bit encryption technology. Data storage encryption of sensitive fields is done. Any bid document that is uploaded to the server is subjected to symmetric encryption using a system generated symmetric key. Further this key is subjected to asymmetric encryption using buyers/bid opener's public keys. Overall, the uploaded tender documents become readable only after the tender opening by the authorized bid openers.
- 8) The uploaded tender documents become readable only after the tender opening by the authorized bid openers.
- 9) Upon the successful and timely submission of bids (i.e. after Clicking "Freeze Bid Submission" in the portal), the portal will give a successful bid submission message & a bid summary will be displayed with the bid no. and the date & time of submission of the bid with all other relevant details.
- 10) The bid summary has to be printed and kept as an acknowledgement of the submission of the bid. This acknowledgment may be used as an entry pass for any bid opening meetings.

## **5 ASSISTANCE TO BIDDERS**

- 1) Any queries relating to the tender document and the terms and conditions contained therein should be addressed to the Tender Inviting Authority for a tender or the relevant contact person indicated in the tender. The contact number of end user is 0512-259-2323. Please call between 10:30 hrs to 17:00 hrs.
- 2) Any queries relating to the process of online bid submission or queries relating to CPP Portal in general may be directed to the 24x7 CPP Portal Helpdesk.



**(Part-B)**  
**Instruction For e-Procurement**

**1 PREPARATION AND SUBMISSION OF BIDS:**

- 1.1 The detailed tender documents may be downloaded from <http://eprocure.gov.in/eprocure/app> till the last date of submission of tender. The Tender may be submitted online through CPP Portal <http://eprocure.gov.in/eprocure/app>
- 1.2 The bidder should submit the bid online in two parts viz. Technical Bid and Financial Bid. Technical Bid should be upload online in cover-1 and Financial Bid in “. Xls” should be upload online in cover-2

**2 SUBMISSION OF THE BID:**

- 2.1 All interested eligible bidders are requested to submit their bids online on CPP Portal: <http://eprocure.gov.in/eprocure/app> as per the criteria given in this document:
- a. Technical Bid should be uploaded online in cover-1.
  - b. Financial Bid should be uploaded online in cover-2.
- Both Technical and Financial Bid covers should be placed online on the CPP Portal (<http://eprocure.gov.in/eprocure/app>).

**3 TECHNICAL BID:**

- 3.1 Signed and Scanned copies of the Technical bid documents as under must be submitted online on CPP Portal: <http://eprocure.gov.in/eprocure/app> .
- i. **List of Documents to be scanned and uploaded (Under Cover-1) within the period of bid submission:-**
    - 1. Scanned copy of Bank details.
    - 2. Scanned copy of work experience.
    - 3. Scanned copy of certificate of GST.
    - 4. Scanned copy of specifications/brochures & tender acceptance letter on Appendix 1-2.
    - 5. Scanned copy of other documents mentioned in tender terms and conditions (if any)
    - 6. Declaration for local content, Country of Origin of goods and Bid Security on Appendix 3-4.
      - (i) For The tender value upto Rs. 10 Crores - Self-Certificate for local content from the bidder.
      - (ii) For the tender value above Rs. 10 Crores - Certificate for local content from Statutory Auditor/Cost Auditor/Cost Accountant/CA.
  - ii. **For Import Shipments - Shipping Terms Ex-Works/FOB are preferred.**

Note: - No indication of the rates/amounts be made in any of the documents submitted with the Technical Bid.

#### **4 FINANCIAL BID**

- 4.1 The currency of all quoted rates shall be Indian Rupees.
- 4.2 In preparing the financial bids, bidders are expected to take into account the requirements and conditions laid down in this Tender document. The financial bids should be uploaded online as per the specified “.Xls” format i.e. Price Bid Excel sheet attached as ‘.Xls’ with the tender and based on the scope of work, service conditions and other terms of the Tender document. It should include all costs associated with the Terms of Reference/Scope of Work of the assignment.
- 4.3 The Financial Proposal should be inclusive of all applicable taxes, duties, fees, levies, and other charges imposed under the applicable laws. The rates quoted in the Tender are inclusive of all applicable taxes, duties etc. **except service tax**. The service tax component shall be re-immersible by the department after receipt of paid challans etc. if applicable.

#### **5 LAST DATE FOR SUBMISSION OF TENDER:**

- 5.1 Online bids complete in all respects, must be submitted on or before the last date and time specified in the schedule of events.
- 5.2 The IIT, Kanpur may, at its own discretion, alter/extend the last date for submission of tenders.

#### **6 BID VALIDITY**

- 6.1 All the Bids must be valid for a period of **120** days from the last date of submission of the tender for execution of Contract. However, the quoted rates should be valid for the initial/ extended period of the Contract from the effective date of the Contract. No request will be considered for price revision during the original Contract period.
- 6.2 A bid valid for a shorter period shall be declared as non-responsive.
- 6.3 In exceptional circumstances, prior to expiry of the original time limit, the IIT may request the bidders to extend the period of validity for a specified additional period beyond the original validity of **120** days. The request and the bidders’ responses shall be made in writing. The bidders, not agreeing for such extensions will be allowed to withdraw their bids without forfeiture of their Bid Security.

#### **7 MODIFICATION / SUBSTITUTION/ WITHDRAWAL OF BIDS:**

- 7.1 No Bid shall be modified, substituted or withdrawn by the Bidder after the due date of the Bid.
- 7.2 Any alteration/ modification in the Bid or additional information supplied subsequent to the Bid's due Date, unless the same has been expressly sought for by the Authority, shall be disregarded.

#### **8 REJECTION OF THE BID:**

- 8.1 The bid submitted shall become invalid and tender fee shall not be refunded if:-

- (a) The bidder is found ineligible.
- (b) The bidder does not upload all the documents as stipulated in the bid document.

## **9 SELECTION CRITERIA:**

### **9.1 PHASE-I: Technical Evaluation**

- a. Technical evaluation will be done on the basis of information given by technical bid submitted by the bidders. A bid containing partial, incomplete, unclear and superfluous and unwanted information will be summarily rejected.
- b. Technical declaration must be supported with relevant documents. Discrepancy in relevant supporting documents and technical compliance sheets will lead to rejection of technical bids.

### **9.2 PHASE-II: Financial Evaluation**

- a. Financial bids of technically qualified bidders shall be opened.
- b. Financial evaluation is purely done on the total financial implication.
- c. Any superfluous, unreasonable assets rate quotes will be summarily rejected.

## **10 Instruction to the bidder of countries which share land border with India (Rule 144(xi) GFRs)**

- 10.1 Any bidder from a country which shares a land border with India will be eligible to bid in this tender only if the bidder is registered with the Department for Promotion of Industry and Internal Trade (DPIIT).
- 10.2 "Bidder" (including the term 'tenderer', 'consultant' or 'service provider' in certain contexts) means any person or firm or company, including any member of a consortium or joint venture (that is an association of several persons, or firms or companies) , every artificial juridical person not falling in any of the descriptions of bidders stated hereinbefore, including any agency branch or office controlled by such person, participating in a procurement process.
- 10.3 "Bidder from a country which shares a land border with India" for the purpose of this Order means: -
  - a. An entity incorporated, established, or registered in such a country; or
  - b. A subsidiary of an entity incorporated, established, or registered in such a country; or
  - c. An entity substantially controlled through entities incorporated, established, or registered in such a country; or
  - d. An entity whose beneficial owner is situated in such a country; or
  - e. An Indian (or other) agent of such an entity; or
  - f. A natural person who is a citizen of such a country; or

- g. A consortium or joint venture where any member of the consortium or joint venture falls under any of the above

10.4 The beneficial owner for the purpose of (iii) above will be as under:

- (a) In case of a company or Limited Liability Partnership, the beneficial owner is the natural person(s), who, whether acting alone or together, or through one or more juridical person, has a controlling ownership interest or who exercises control through other means .

**Explanation-**

- a. "Controlling ownership interest" means ownership of or entitlement to more than twenty-five per cent. of shares or capital or profits of the company.
- b. "Control" shall include the right to appoint majority of the directors or to control the management or policy decisions including by virtue of their shareholding or management rights or shareholders agreements or voting agreements.
- (b) In case of a partnership firm, the beneficial owner is the natural person(s) who, whether acting alone or together, or through one or more juridical person, has ownership of entitlement to more than fifteen percent of capital or profits of the partnership;
- (c) In case of an unincorporated association or body of individuals, the beneficial owner is the natural person(s), who, whether acting alone or together, or through one or more juridical person, has ownership of or entitlement to more than fifteen percent of the property or capital or profits of such association or body of individuals;
- (d) Where no natural person is identified under (1) or (2) or (3) above, the beneficial owner is the relevant natural person who holds the position of senior managing official.
- (e) In case of a trust, the identification of beneficial owner(s) shall include identification of the author of the trust, the trustee, the beneficiaries with fifteen percent or more interest in the trust and any other natural person exercising ultimate effective control over the trust through a chain of control or ownership.

10.5 An Agent is a person employed to do any act for another, or to represent another in dealings with third person.

10.6 In case of tenders for Works contracts, including Turnkey contracts, the successful bidder shall not be allowed to sub-contract works to any contractor from a country which shares a land border with India unless such contractor is registered with the Competent Authority.

## **11 MII & Purchase Preference:**

11.1 As per the Ministry of Commerce and Industry Order No. P-45021/2/2017-PP(BE-II) dated 04.06.2020 preference shall be given to Make in India products for which it

is mandatory for bidders to declare Country of Origin of goods and percentage of Local contents in the product.

**Definitions:**

“**Local Content**” means the amount of value added in India which shall, unless otherwise prescribed by the Nodal Ministry, be the total value of the item procured (excluding net domestic indirect taxes) minus the value of imported content in the item (including all customs duties) as a proportion of the total value, in percent.

“**Class-I Local Supplier**” means a supplier or service provider, whose goods, services or works offered for procurement, has local content to or more than 50%, as defined under this order.

“**Class-II Local Supplier**” means a supplier or service provider, whose goods, services or works offered for procurement, has local content more than 20% but less than 50%, as defined under this order.

“**Margin of Purchase Preference**” means the maximum extent to which the price quoted by a Class-I local supplier may be above the L1 for the purpose of purchase preference. (Shall be 20%)

**Purchase Preference:**

- (a) Subject to the provisions of this Order and to any specific instructions issued by the Nodal Ministry or in pursuance of this Order, purchase preference shall be given to 'Class-I local supplier' in procurements undertaken by procuring entities in the manner specified here under.
- (b) In the procurements of goods or works, which are covered by para 3(b) above and which are divisible in nature, the Class-I local supplier' shall get purchase preference over 'Class-II local supplier' as well as 'Non-local supplier', as per following procedure:
  - (i) Among all qualified bids, the lowest bid will be termed as L1. If L1 is Class local supplier', the contract for full quantity will be awarded to L1.
  - (ii) If L1 bid is not a 'Class-I local supplier', 50% of the order quantity shall be awarded to L1. Thereafter, the lowest bidder among the 'Class-I local supplier' will be invited to match the L1 price for the remaining 50% quantity subject to the Class-I local supplier's quoted price falling within the margin of purchase preference, and contract for that quantity shall be awarded to such 'Class-I local supplier' subject to matching the L1 price. In case such lowest eligible 'Class-I local supplier' fails to match the L1 price or accepts less than the offered quantity, the next higher 'Class-I local supplier' within the margin of purchase preference shall be invited to match the L1 price for remaining quantity and so on, and contract shall be awarded accordingly. In case some quantity is still left uncovered on Class-I local suppliers, then such balance quantity may also be ordered on the L1 bidder.
- (c) In the procurements of goods or works, which are covered by para 3(b) above and which are not divisible in nature, and in procurement of services where

the bid is evaluated on price alone, the 'Class-1 local supplier' shall get purchase preference over 'Class-II local supplier' as well as 'Non-local supplier', as per following procedure:

- (i) Among all qualified bids, the lowest bid will be termed as L1. If L1 is 'Class-1 local supplier', the contract will be awarded to L1.
  - (ii) If L1 is not 'Class-1 local supplier', the lowest bidder among the 'Class-II local supplier', will be invited to match the L1 price subject to Class-II local supplier's quoted price falling within the margin of purchase preference, and the contract shall be awarded to such 'Class-II local supplier' subject to matching the L1 price.
  - (iii) In case such lowest eligible 'Class-1 local supplier' fails to match the L1 price, the 'Class-1 local supplier' with the next higher bid within the margin of purchase preference shall be invited to match the L1 price and so on and contract shall be awarded accordingly. In case none of the 'Class-1 local supplier' within the margin of purchase preference matches the L1 price, the contract may be awarded to the L1 bidder.
- (d) "**Class-II Local Supplier**" will not get purchase preference in any procurement undertaken by procuring entities.

## 12 Benefits:

12.1 Bidders will get all benefits under Rule-153 of GFR, 2017.

**(Part-C)**  
**Commercial Terms and Conditions**

**13 DEFINITIONS**

These Commercial Terms and Conditions shall constitute the General Conditions of Contract, where no separate contract is signed with the selected Bidder(s), and, the Bidders by putting their signature and stamp on each page of this Section V are binding themselves to these Terms and Conditions. In the Commercial Terms and Conditions as defined below, words and expressions shall have the following meanings assigned to them:

- 1.1 **“Contract”** means the agreement of the Parties relating to the procurement of Goods and / or the IITK Purchase Order (PO), and all attachments incorporated by reference, which shall form an integral part of the Contract. In the event of any discrepancy, the documents to prevail shall be given precedence in the following order: (i) the Contract (where separately signed), (ii) the IITK Purchase Order, (iii) its attachments, and (iv) these Commercial Terms and Conditions.
- 1.2 **“Contractor”** means the person or entity named in the ‘CONTRACTOR’ named field of the IITK Purchase Order and any agreed in writing by the IITK legal successor(s) in title.
- 1.3 **“Day”** means any calendar day.
- 1.4 **“Delivery Date”** means the latest possible date by which the Goods shall be delivered by the Contractor to the IITK, as specified in the ‘DELIVERY DATE’ named field of the IITK Purchase Order.
- 1.5 **“Force Majeure”** shall mean any unforeseeable exceptional situation or event beyond the Parties’ control which prevents either of them from fulfilling any of their obligations under the Contract, was not attributable to error or negligence on their part (or of their partners, contractors, agents or employees), and could not have been avoided by the exercise of due diligence. Defects in equipment or material or delays in making them available, labour disputes, strikes or financial problems cannot be invoked as Force Majeure by the defaulting Party. Neither of the Parties shall be held liable for breach of its obligations under the Contract if it is prevented from fulfilling them by Force Majeure. The Party invoking Force Majeure shall notify the other without delay, stating the nature, likely duration and foreseeable effect, and take any measure to minimize possible damage.
- 1.6 **“Goods”** means all of the goods to be supplied to the IITK by the Contractor under the Contract.
- 1.7 **“IITK”** means the Indian Institute of Technology Kanpur.
- 1.8 **“IITK Purchase Order”** means the IITK’s official Purchase Order document.
- 1.9 **“Party”** means the IITK, or the Contractor and **“Parties”** means the IITK and the Contractor; and **“Place(s) of Delivery”** means the location(s) or place(s) where the Goods are to be delivered, as specified in the ‘SHIP TO’ named field of the IITK Purchase Order.

## **14 CONCLUSION OF THE CONTRACT**

- 2.1. The Contract is made between the IITK and the Contractor. The Contractor is engaged as an independent contractor for the sole purpose of delivering the Goods.
- 2.2. The Contract shall be concluded upon the Contractor duly following the countersigning procedure as stated in the IITK Letter of Intent (LOI).

## **15 FUNDING**

- 3.1 This Contract shall become and remain effective only on the condition that an official Purchase Order is issued by IITK following the conclusion of tender exercise. In the event this is not or no longer shall the case, the IITK without unreasonable delay notify the Contractor thereof.
- 3.2 Any continuation of the Contractor's performance under this Contract after being notified by the IITK shall be at the Contractor's risk and expense.

## **16 DELIVERY AND TAKE-OVER OF GOODS**

- 4.1 The Contractor shall deliver the Goods at the Place(s) of Delivery. On behalf of the IITK, a duly authorised representative(s), shall take-over the Goods upon delivery. Take-over of the Goods by the IITK shall not be deemed acceptance of the Goods by the IITK. The time of delivery as specified in the Contract / PO shall be strictly adhered to, and time shall be of the essence.

## **17 QUALITY OF GOODS**

- 5.1 The Contractor shall deliver Goods that are:
  - a. of the quality, quantity and description as required by the Contract / PO; and
  - b. Free from any right or claim of a third party, including rights based on industrial property or other intellectual property.
- 5.2 Should the Goods be of the type "homogeneously defined" or disposable, the Contractor shall undertake, certify, and guarantee that all Goods delivered shall be of the same quality and characteristics as mentioned in the specifications.

## **18 INSPECTION AND ACCEPTANCE**

- 18.1 The duly authorized representative(s) of the IITK shall have the right, before payment, to inspect the Goods either at the Contractor's stores, during manufacture, at the ports and/or in places of shipment, or at the Place(s) of Delivery. The Contractor shall provide all facilities for such inspection. The IITK may issue a written waiver of inspection. Any inspection carried out by representative(s) of the IITK, or any waiver thereof shall be without prejudice to other provisions of the Contract concerning obligations assumed by the Contractor, including specifications of the Goods.
- 6.2 Upon delivery and inspection of the Goods, the IITK shall inspect the goods as soon as possible and complete the Goods Receiving Document. Should any Goods fail to conform to the technical specifications, codes and standards under the Contract, the IITK may reject the Goods. The Contractor shall, at no cost to the IITK, replace the rejected Goods or, alternatively, rectify the non-conformity.



- 6.3 In the case of Goods ordered on the basis of specifications, the IITK shall have the right to reject the Goods or any part thereof and terminate the Contract if the Goods do not conform to the specifications. Nothing in this clause shall in any way release the Contractor from any warranty or other obligations under the Contract.

## **19 SHIPPING AND INSURANCE**

- 7.1 For overseas orders, shipping arrangements shall be co-ordinated by IITK. Original shipping documents including the packing list shall be airtailed/mailed by the Contractor to the (Assistant Registrar (S&P), IIT, Kanpur – 208 016, UP, India).

## **20 OBSERVANCE OF LAW AND EXPORT LICENCES**

- 8.1 The Contractor shall comply with all laws, ordinance, rules and regulations bearing upon the performance of its obligations under the terms of the Contract. If an export licence or any other governmental authorisation is required for the Goods, it shall be the obligation of the Contractor to obtain such licence or governmental authorisation. In the event of the Contractor's failure to obtain such licence or authorisation within a reasonable time, the IITK may immediately terminate the Contract. Where the award procedure or execution of the Contract is vitiated by substantial errors or irregularities or by fraud, the IITK shall suspend execution of the Contract.
- 8.2 Where such errors, irregularities or fraud are attributable to the Contractor, the IITK may also refuse to make payments or may recover monies already paid, in proportion to the seriousness of the errors, irregularities or fraud. The purpose of suspending the Contract shall be to verify whether presumed substantial errors and irregularities or fraud have actually occurred. If they are not confirmed, execution of the Contract shall resume as soon as possible. A substantial error or irregularity shall be any infringement of a contract or regulatory provision of India, resulting from an act or an omission that causes or might cause a financial loss.

## **21 PRICE**

- 9.1 The price of the Goods shall be as stated in the Purchase Order and may not be increased.

## **22 PAYMENT**

- 22.1 Unless otherwise stipulated in the Purchase Order, the IITK shall make payment within thirty (30) Days of the later of:
- a. Successful delivery of the goods to IITK as confirmed by the consignee (Assistant Registrar, Store & Purchase, IIT-Kanpur), endorsed by the indenter and approved by the indenters' Head of Department / Section.
  - b. Receipt of customary shipping documents and any other documents specified in the Contract; and (c) Receipt of the original invoice issued by the Contractor.

- 22.2 All invoices shall be in original and shall contain the IITK Purchase Order number, and a description, the quantities, unit and total price(s) of the Goods delivered. The currency of the invoice and payment shall be as specified in the Purchase Order. Unless otherwise authorized by the IITK, a separate invoice shall be submitted for each shipment under the Contract / PO. Subject to Clause 11 below ('Tax Exemption'), if applicable, the GST amount shall be separately identified in the invoice.
- 22.3 Payments shall be made in the currency stated in the Contract / PO, on the basis of the equivalent value of INR on the day of payment and paid directly into the nominated bank account.
- 22.4 The IITK shall not pay any charge for late payments.

## 23 TAX EXEMPTION

- 23.1 The Contractor's price shall reflect any tax exemption to which the IITK is entitled. If it is subsequently determined that any taxes that have been included in the price are not required to be paid or if, having been paid, any such taxes are subject to refunding, the IITK shall deduct the amount from the Contract price. Payment of such adjusted amount shall constitute full payment by the IITK. In the event that any taxing authority refuses to recognize the IITK's exemption from taxes, the Contractor shall immediately consult with the IITK to determine a mutually acceptable procedure for settling the applicable amount.

## 24 WARRANTY

- 24.1 The Contractor warrants that the Goods furnished under the Contract conform to the technical specifications, description and standards specified in the Contract, and are new and unused, and free from defects in design, workmanship and/or materials.
- 24.2 The Contractor shall provide a warranty for the Goods for a period of one year from the date of acceptance of the Goods by the IITK, unless the standard manufacturer's warranty period is longer in which case the longer period shall apply.
- 24.3 In the case of "homogeneously defined" or disposable goods, should any portion of the Goods, at any time, not comply with clause 5.1 or 5.2 herein or otherwise prove to be defective, the Contractor shall, upon written notification from the IITK, replace that portion of the Goods and bear all costs associated with the replacement of same.

## 25 PACKING

- 25.1 The Goods shall be packed and marked in a proper manner and in accordance with the Contract and any statutory requirements and any requirements of the carrier(s). In particular, the Goods shall be marked with the IITK Purchase Order number and the net, gross and tare weights, the name of the contents shall be clearly marked on each container and all containers of hazardous goods (and all documents relating thereto) shall bear prominent and adequate warnings.
- 25.2 The Contractor shall provide such packing of the Goods as is required to prevent their damage or deterioration during transit to their final destination. The packing shall be sufficient to withstand, without limitation, rough handling during transit. Packing case size and weights shall take into consideration, where appropriate, the remoteness of the final destination and the absence of appropriate handling facilities at all points in transit.
- 25.3 All packaging materials shall be non-returnable.

## 26 DEFAULT AND DAMAGES

- 26.1 If due to reasons attributable to the Contractor, the Contractor fails or refuses to:
- a. deliver any or all of the Goods under the Purchase Order.
  - b. comply with any or all of the terms and conditions set out in the Purchase Order; or
  - c. deliver any or all of the Goods under the Purchase Order on or before the Delivery Date; the IITK may hold the Contractor in default under the Purchase Order.
- 26.2 When the Contractor is thus in default, the IITK may, by written notice to the Contractor, immediately terminate the Purchase Order in whole or in such part or parts thereof in respect of which the Contractor is in default.
- 26.3 Alternatively, to clause 14 above when the Contractor is thus in default, the IITK may, at its own discretion, set a reasonable period of time for the Contractor to remedy its default. Any new Delivery Date shall be specified in a written amendment to the Purchase Order, duly countersigned by the Contractor.
- 26.4 The IITK may, at its discretion, impose penalties upon the Contractor calculated in accordance with clause 15 for each Day the Contractor is late in delivering the Goods past the Delivery Date initially specified in the Purchase Order.
- 26.5 If the Contractor does not remedy its default within the period accorded under clause 16, the IITK may, by written notice to the Contractor, terminate the Purchase Order with immediate effect.
- 26.6 Upon any termination of the Purchase Order, in whole or such part(s) thereof in respect of which the Contractor is in default, the IITK may engage another contractor to deliver the Goods and recover any difference in price and any additional costs from the Contractor.
- 26.7 The Contractor shall indemnify the IITK for all losses, charges, costs and expenses, which the IITK may suffer or incur as a result the Contractor's default, including those resulting from engaging another contractor pursuant to this clause 14.

## 27 PENALTIES

- 15.1 If, in accordance with clause 15, the IITK imposes penalties on the Contractor, such penalties shall amount to point five percent (0.5%) of the total Purchase Order price for each week following the initial Delivery Date specified in the Purchase Order but shall not amount to more than Ten percent (10%) of the total Purchase Order value. The penalties for the delay may be deducted by IITK from any sum(s) due, or to become due, by the IITK to the Contractor.

## 28 DELAY NOT ATTRIBUTABLE TO THE CONTRACTOR

- 16.1 If the Contractor is delayed at any time in the delivery of the Goods or fulfilment of any other of the Contractor's obligations by any act or omission of the IITK, or by any of its officials, or by any separate contractor(s) contracted by the IITK, or by changes ordered in the type and/or quantity of the ordered Goods, or the Place(s) of Delivery, or any causes beyond the Contractor's reasonable control, or by any other cause, which the IITK determines may reasonably justify the delay, the Delivery Date of the Goods, or fulfilment of any other of the Contractor's applicable obligations shall be extended for such reasonable period of time as the IITK and the Contractor mutually determine. The set reasonable period of time and any amended delivery date shall be specified in a written amendment to the Contract / PO, duly countersigned by the Contractor.

## **29 FORCE MAJEURE**

17.1 As soon as possible after the occurrence of any event constituting Force Majeure, but no later than three (3) Days, the Contractor shall give notice and full particulars in writing to the IITK of the Force Majeure. If the Contractor is thereby rendered unable, wholly or in part, to meet its obligations under the Contract, the IITK may terminate the Contract / PO with immediate effect by providing written notice to the Contractor.

## **30 INDEMNITY**

18.1 The Contractor shall indemnify, hold and save harmless and defend at its own expense the IITK, and all of the foregoing's officials, agents, servants and employees from and against all suits, claims, demands and liability of any nature or kind, including costs and expenses, arising out of acts or omissions of the Contractor or its employees, agents or subcontractors in the performance of the Contract.

18.2 Clause 18 shall include, without limitation, claims and liabilities in the nature of workmen's compensation and claims and liabilities arising out of the use of patented inventions or devices.

## **31 ASSIGNMENT**

19.1 The Contractor shall not assign, transfer, pledge or make other disposition of the Purchase Order or any part thereof or of any of the Contractor's rights, claims or obligations under the Purchase Order except with the express written consent of the IITK. Any assignment made without such consent shall be void and of no effect.

19.2 The Contractor shall not subcontract any of its obligations under the Contract / PO without the express written consent of the IITK. The IITK may require the Contractor to furnish particulars of the proposed subcontract as the IITK deems necessary.

19.3 The IITK's approval of any subcontracting shall not relieve the Contractor from any liability or obligation under the Contract. In any subcontract, the Contractor agrees to bind the subcontractor by the same terms and conditions by which the Contractor is bound under the Contract / PO.

## **32 INSOLVENCY AND BANKRUPTCY**

20.1 Should the Contractor become insolvent or should control of the Contractor change by virtue of insolvency, the IITK may with immediate effect and without prejudice to any other right or remedy available to it, suspend the performance of the Contractor's obligations or terminate the Purchase Order with immediate effect, by providing the Contractor with written notice thereof.

20.2 Should the Contractor be adjudged bankrupt, or should the Contractor make a general assignment for the benefit of its creditors, or should a receiver be appointed on account of the Contractor's insolvency, the IITK may, without prejudice to any other right or remedy available to it, terminate the Purchase Order with immediate effect by providing the Contractor with written notice thereof.

### **33 TERMINATION**

33.1 The IITK shall have the right to terminate the Purchase Order or any of the provisions thereof at any time by serving a three days' notice to the Contractor.

### **34 WAIVER**

22.1 A waiver of any breach of or default under the Contract / PO shall not constitute a waiver of any other breach or default and shall not affect the other terms of the Contract / PO. The rights and remedies provided by the Purchase Order are cumulative and are not exclusive of any other rights or remedies.

### **35 ADVERTISING**

23.1 The Contractor shall not advertise or otherwise make public the fact that it is a contractor to the IITK. The Contractor shall not in any way use the name, emblem, logo, official seal, or any abbreviation of the IITK.

### **36 DISCRETION AND CONFIDENTIALITY**

24.1 The Contractor is required to exercise the utmost discretion in all matters relating to the Contract / Purchase Order. Unless required in connection with the performance of the Purchase Order or expressly authorised in writing by the IITK, the Contractor shall not disclose at any time to any third party any information which has not been made public and which is known to the Contractor by reason of its association with the IITK. The Contractor shall not, at any time, use such information to any private advantage. These obligations do not lapse upon any completion, expiration, cancellation or termination of the Contract / PO.

### **37 NOTICES**

25.1 Any notice given in connection with the Contract shall be given in English and in writing and shall be deemed to be validly given if sent by registered mail or by fax or by email to the other Party at the following:

- a. for the IITK: the contact details set out in the 'IITK BUYER' name field of the Purchase Order; and
- b. for the Contractor: the contact details set out in the 'CONTRACTOR' named field of the IITK Contract/Purchase Order.

### **38 STAFF MEMBERS NOT TO BENEFIT**

26.1 The Contractor shall not grant to any official of the IITK any direct or indirect benefit or preferential treatment on the basis of the Purchase Order or the award thereof. Any breach of this provision shall constitute a fundamental breach of the Purchase Order.

### **39 GOVERNING LAW**

27.1 The Contract shall be governed by and construed in accordance with the substantive laws of the Republic of India.

#### **40 SETTLEMENT OF DISPUTES**

40.1 The Parties shall use their best efforts to negotiate and amicably settle any disputes, controversies or claims arising out of, or in connection with, the Contract / Purchase Order or its interpretation.

40.2 If the Parties fail to settle the dispute amicably within thirty (30) Days of commencement of the negotiations, the dispute shall be settled through arbitration. One (1) sole arbitrator shall be appointed by the Director of IITK who full powers shall have to make final and binding decisions subject to prevailing laws of India. The appointing authority shall be the Director of IITK. The place of arbitration shall be Kanpur, and the language used in the arbitration proceedings shall be English.

#### **41 PRIVILEGES AND IMMUNITIES**

29.1 No provision of the Contract / Purchase Order shall be deemed, or interpreted as, a waiver of the privileges and immunities enjoyed by the IITK.

#### **42 AMENDMENTS**

30.1 No modification, amendment or change to the Contract/Purchase Order, or waiver of any of its provisions, or any additional contractual relationship with the Contractor shall be valid unless approved in the form of a written amendment to the Contract/Purchase Order, signed by a fully authorised representative of each Party.

#### **43 VALIDITY**

31.1 The invalidity in whole or part of any condition of the Contract / Purchase Order or clause thereof shall not affect the validity of the remainder of such condition or clause.

#### **44 ENTIRE AGREEMENT**

32.1 The Contract / Purchase Order constitute the entire agreement and understanding of the Parties and supersede any previous agreement, whether orally or in writing, between the Parties relating to the subject matter of the Contract.

#### **45 GOVERNING LANGUAGE**

33.1 The Contract / Purchase Order shall be executed in the English language which shall be the binding and controlling language for all matters relating to the meaning and interpretation of the Contract / Purchase Order.

## Tender document

NIT No.: IITK/SEE/SCU/SOLAR/2024/01 \_\_\_\_\_ Dated: 11/11/2024

Tender for : *“Supplying, Installation, Commissioning, and Testing of grid-connected 100 kW solar PV plant at The Sindhu Central University (SCU) - Khalatse, Ladakh, India.*

### **About:-**

Coordinates: 34.3192846, 76.8918722

Address: SINDHU CENTRAL UNIVERSITY transit campus, near Govt. Degree college, Khaltse, Leh-Kargil Highway, LEH, Ladakh-194106

Online quotations are invited for: *“Design, Supplying, Installation, Commissioning, and Testing of grid-connected 100 kW solar PV plant at The Sindhu Central University (SCU) - Khalatse, Ladakh, India.*

### **Initial Eligibility & Technical Criteria:**

- I. **Joint ventures are not accepted.** The bidders satisfying the initial eligibility & Technical criteria shall only be considered for financial bid opening.
- II. Vendor/OEM should be MNRE approved.
- III. Vendor shall have done some similar work for Central Government / State Government / Central Autonomous Body / Central PSUs with 3 (three) similar completed works costing not less than *Rs. 20 Lakhs (INR)* or 2 (two) similar completed works, not less than *Rs 25 Lakhs* or 1 (one) similar completed work of aggregate cost not less than *Rs. 40 Lakhs*.  
**Note: - The similar nature works means experience of Supply, installation, testing & commissioning of roof top solar PV system with grid tied inverter and associated controls.**
- IV. Should have average annual financial turnover of **Rs. 3 crore** of similar works during any three financial years in the last 5 financial years ending 31-03-2024.
- V. Should not have incurred any loss in more than two years during the last five years ending 31-03-2024.
- VI. Should have valid registration of ESIC and GST.
- VII. The time allowed for carrying out the work will be 06 Months from the date of the Purchase Order, whichever is later, in accordance with the phasing, if any, indicated in the tender documents.
- VIII. The site for the work is available for the execution of the works.
- IX. Intending Tenderers are advised to inspect and examine the site and its surroundings and satisfy themselves before submitting their tenders as to the nature of the terrace/ground and sub-soil (so far as is practicable), the form and nature of the site, the means of access to the site, the accommodation they may require and in general shall themselves obtain all necessary information as to risks, contingencies and other circumstances which may influence or affect

their tender. A tenderers shall be deemed to have full knowledge of the site whether he inspects it or not and no extra charge consequent on any misunderstanding or otherwise shall be allowed.

- X. The principal investigator (PI), IIT Kanpur does not bind itself to accept the lowest or any other tender and reserves to itself the authority to reject any or all the tenders received without the assignment of any reason. All tenders in which any of the prescribed condition is not fulfilled or any condition including that of conditional rebate is put forth by the tenderers shall be summarily rejected.
- XI. No Engineer of Gazetted Rank or other Gazetted Officer employed in Engineering or Administrative duties in an Engineering Department of the Government of India is allowed to work as a contractor for a period of one year after his retirement from Government service, without the prior permission of the Government of India in writing. This contract is liable to be cancelled if either the contractor or any of his employees is found any time to be such a person who had not obtained the permission of the Government of India as aforesaid before submission of the tender or engagement in the contractor's service.
- XII. Entire work under the scope of composite tender including major and all minor components shall be executed under one agreement.
- XIII. Security Deposit will be worked out separately for each component corresponding to the estimated cost of the respective component of works. The Earnest Money will become part of the security deposit of the major components of work.

**\*\*IIT Kanpur holds the right to modify/cancel the tender\*\***

***Principal Investigator***



# TECHNICAL SPECIFICATION

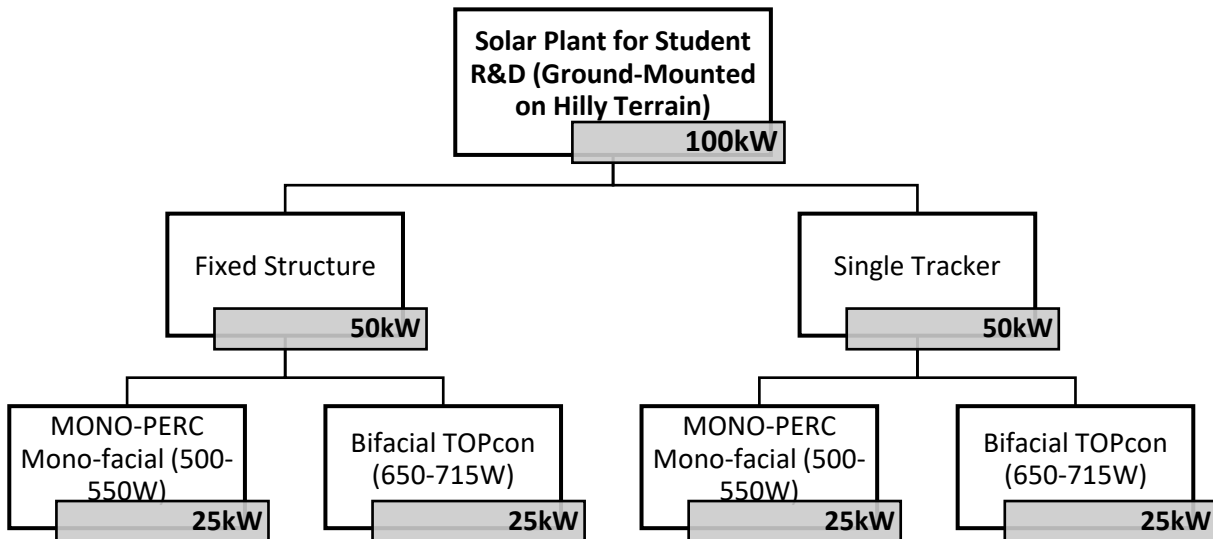

## Section 1: Solar PV Panels and mounting structure

## Section 2: Inverters

## Section 3: Electrical Works

### SECTION 1 : SOLAR PV PANEL

1. The SPV array generally consists of the number of SPV modules that directly produce DC electricity power on receipt of solar radiation. This DC power is converted to AC power by inverter. The AC output of the 100 kW solar plant at 415 V level will work in combination with the SCU available grid, feeding the existing LT system at the available transit campus building's LT panels. Modules may be connected in series or parallel to increase the voltage and current and to achieve the required solar array characteristics that will match the load.
2. Solar PV modules/Panels should be mono-PERC/TopCon or equivalent cells and shall have high efficiency and be of Indian origin (cells of the panel may be overseas made).
3. The Stabilized output of solar Power plant shall be 100 kWp DC after One year (the stability will be checked based on **PR and CUF** basis). The bidder shall demonstrate the capacity of plant after One year from the date of commissioning of plant and shall also be part of guarantee. The bidder shall use adequate capacity of SPV module, Inverter, Junction boxes etc. to ensure generation of power as per design estimates. This is to be done by applying liberal de-rating factors for the array and recognizing the efficiency parameters of Inverter etc. The output at Inverters (s) will be considered for verification purpose. Bidder shall indicate procedure and details of software or formula for demonstration of capacity of plant in tender itself. For other purpose the meter reading will be considered.
  - a) Selection of the equipment and adoption of a plant layout to ensure ease of maintenance.
  - b) Ripple content must not exceed **3%** on DC side.

- c) Overall shading losses should be less than **2%**.
  - d) The power plant shall operate in parallel with the grid system which is infinite electrical system. Any faults not taken care will result in damage of only SPV power plant without effecting IIT Kanpur grid infinite system. Thus the Solar Power Plant has to protect its equipment against any of possible fault or other disturbances from the grid.
4. The basic and detailed engineering of the plant will aim at achieving high standards of operational performance especially considering following:
- a) Optimum availability of modules during the day time.
  - b) Ensuring module layout to prevent shading.
  - c) Selection of Inverter with high track record and readily availability of requisite spares.
  - d) Flat plate arrays are held fixed at a tilted angle and face towards the equator. The angle of tilt should be approximately equal to the angle of latitude for the site. A steeper angle increases the output in winter: while a shallower angle, more output in summer. It should be arranged in such a manner that optimize generation is achieved.
  - e) Based on the Solar insolation data, the solar PV system should be so designed that it shall take into account the mean energy output after allowing for various losses, and temperature correction, on an average day for each month of the year.
  - f) Only **OEM-certified Grade-A panels**; the authentic certificate should be provided by the vendor with model Nos. mentioned in the certificate; otherwise, the testing charge shall be borne by the bidder.

### **A. Solar PV Module Specifications:-**

- 1.1. The equipment and material for a 100kWp Solar Photovoltaic Power Plant with associate system (typical) shall include the following but not be limited to the following: (Only The technical features of major equipment's are described here under).
- 1.2. **SPV MONO PERC Mono-facial solar panels to be supplied, shall have a declared output of 500-550 Watt peak. The number of modules to be supplied will be as per calculation; for 50kW.**
- 1.3. **Hi-efficiency Bifacial TOPCon panel to be supplied, shall have declared output of 650-715 Watt peak. The number of modules to be supplied will be as per calculation; for another 50kW.**
- 1.4. Stabilized output of the Solar Power Plant should not be less than 100kWp under Standard Test Condition after one year of operation from date of Commissioning of solar plant.
- 1.5. SPV modules should be *PID free (PID certified)*.
- 1.6. Each module shall have low iron tempered glass front for strength & superior light transmission. It shall also have tough multi-layered polymer back sheet for environmental

protection against moisture & provide high voltage electrical insulation.

- 1.7. The module frame shall be made of hot dipped Galvanized (at least 85 microns) iron for mounting the PV modules. The thickness of section should not be less than 2 new. The legs / columns of the structure shall be self-supported/ standing. The supports shall be design to given required orientation to take maximum ionization, absorb and transfer the mechanical loads to the ground properly.
- 1.8. SPV module shall contain high power silicon solar cells. The solar cell shall have surface anti-reflective coating to help to absorb more light in all weather conditions (latest technology).
- 1.9. The solar modules shall have suitable encapsulation and sealing arrangements to protect the silicon cells front the environment. The arrangement and the material of encapsulation shall be compatible with the thermal expansion properties of the Silicon cells and the module framing arrangement/material. The encapsulation arrangement shall ensure complete moisture-proofing during the entire life of the solar modules. Protective devices against surges at the PV module shall be provided. Low voltage drop bypass diodes shall be provided. The module frame shall be made of corrosion-resistant materials having anodized aluminium or as per manufacturer standard.
- 1.10. Photo conversion efficiency of the SPV Module should be **greater than 20.5% for MONO-PERC mono-facial and greater than 22.5% for Bifacial TOPCon.** Module shall be made of high transmittance glass front surface giving high encapsulation gain.
- 1.11. Module rating is considered under standard test conditions, however, Solar Modules shall be designed to operate and perform under site conditions including high temperature & dust (sometimes).
- 1.12. All materials used shall be having a proven history of reliable, lightweight, and stable operation in external outdoor applications.
- 1.13. Solar PV Module design shall conform to the following requirements: Weatherproof DC-rated MC connector and a lead cable coming out as a part of the module, making connections easier and secure (not allowing for any loose connections).
- 1.14. Resistant of water, abrasion, hail impact, humidity & other environmental factor for the worst situation at the site.
- 1.15. Other general requirements for the PV modules and subsystems shall be the Following:
  - The rated output power of any supplied module shall have a tolerance of 3% (three percent).
  - The peak-power point voltage and the peak-power point current of any supplied module and/or any module string (series connected modules) shall not vary by more than 2% (two percent) from the respective arithmetic means for all modules and/or for all module strings, as the case may be.
  - The module shall be provided with a junction box with weatherproof lid of sealed type and IP-65/66/67 rated.

- **Warranties:** The MONO-PERC monofacial solar panels must be warranted for output wattage, which should not be less than 90% at the end of 10 years and not less than 80% at the end of 27 years; whereas the Bifacial TOPcon panels must be warranted for output wattage, which should not be less than 94% at the end of 12 years and not less than 85% at the end of 30 years.
- Each PV module used in any solar plant shall use a RF identification tag. The following information must be mentioned in the RFID used on each module. (This can be inside or outside the laminate, but must be able to withstand harsh environmental conditions)
  - Name of the manufacturer of PV module
  - Name of the manufacturer of Solar cells
  - Month and year of the manufacturer (Separately for Solar cell and module)
  - Country of origin (Separately for Solar cell and module)
  - I-V curve for the module
  - Wattage,  $I_m$ ,  $V_m$ , and FF for the module
  - Unique Serial No and Model No of the module
  - Date and year obtaining IEC PV module qualification certificate
  - Name of the test lab issuing the IEC certificate
  - Other relevant information on the traceability of Solar cells and modules as per ISO 9001 & ISO 14001.

## **B. MODULE MOUNTING STRUCTURE:-**

1. There are four types of structures required: two fixed (25kW each) and two single (1-D) trackers (25kW each) based on the type of solar panel.
2. The **hilly terrain** should be considered for structure design and tilt angle calculations as per the site's requirement.
3. MS Galvanized mounting structure cold formed members 2mm (or more) thick with a galvanizing coating of 85 microns is to be used as per requirements of this project and maximum nos. of modules is to be installed in min. area.
4. The structure design shall be appropriate, innovative and corrosion resistant, and compatible with the materials used in the module frame, its fasteners, nuts, and bolts. The bidder may choose to offer a module mounting structure as per their design fulfilling the detailed in NIT and shall be capable of withstanding **wind speed of 180 kmph**.
5. The module alignment & tilt angle shall be calculated to provide the maximum annual energy output to take maximum insolation. This shall be decided based on the location of the array installation (around 25 degrees).
6. The structure shall be designed to allow easy replacement of any module and shall be in line with site requirements. The structure shall be supplied complete with all members to be compatible for allowing easy installation at the site.
7. The rooftop-mounted structure shall be designed for simple mechanical and electrical installation. It shall support SPV modules at a given orientation, absorb and transfer the mechanical loads to the base properly.

7. The mounting steel structure shall be as per latest BIS 2062 (amended up to date) and galvanization of mounting structure shall be in compliance of BIS 4759 (amended up to date). The array structure shall be so designed that it will occupy minimum space without sacrificing the output from SPV panels. The minimum clearance of the structure from the ground level should be **2100mm for both fixed and tracker mounted panels**. Adequate spacing shall be provided between any two modules secured on PV panel for improved wind resistance. The structure shall be designed to withstand operating environmental conditions for a period of minimum 30 years.
8. All fasteners, nut and bolts are made of Stainless steel - SS 304 (1 bolt+2 plain washer+ 1 spring washer+ 1 nut). *The structure shall be strengthened by PCC foundation cubes/block at locations the consideration of **wind speed should be 180 kmph and other considerations such as Snow**.*
9. The array structure shall be grounded properly as per industrial standards.

## **SECTION 2: SOLAR INVERTER**

1. Solar inverter shall be grid interactive in nature and mainly consist of dual MPPT (with Multiple string inputs) controller, **inverter of rating 25kWp, 3 phase, 415 V, IP 65/66/67** each, associated control and protection devices etc. all integrated. It shall provide necessary protections for Grid Synchronization and Data Logging/Monitoring . The inverter shall have communication protocol RS485 over Modbus / Ethernet / Wi-Fi for remote monitoring. The inverter should convert DC power produced by the PV modules into AC power and must synchronize automatically its AC output to the exact AC Voltage and frequency of Grid.
2. Inverters must be PID enabled.
3. The DC energy produced shall be utilized to maximum and supplied to the bus for inverting to AC voltage to extract maximum energy from the solar array and provide 3-ph, 415V AC (-10% to +15%), 50+/- 3% Hz. to synchronize with the grid.
  - a) The inverter shall be of very high quality having **efficiency not less than 98%** and shall be capable of running in integrated mode.
  - b) The degree of protection of the inverter shall be at least IP-65/66/67 for outdoor. Logged data must be directly accessible to IIT Kanpur and made available to the internally designated data servers. In any circumstance, no process or performance data acquired through any data acquisition component of the installation shall be routed through the vendor website or any data server external to IIT Kanpur. This clause must be strictly enforced.
  - c) The inverter shall be designed for continuous, reliable power supply as per specification.
  - d) The inverter shall be capable of complete automatic operation, including wake-up, synchronization & shutdown independently& automatically.
  - e) Both AC & DC lines shall have suitable fuses/MCB/MCCBs Metal Oxide Arrestors/surge

arrestors and contactors to allow safe start-up and shut down of the system. Fuses/MCB/MCCBs used in the DC circuit should be DC-rated.

- f) The inverter shall operate in sleeping mode when there will be no power connected.
- g) The following Protections must be included and operational at all times of inverter operation
  - I. Over voltage both at input & output.
  - II. Over current both at input & output.
  - III. Over/under grid frequency.
  - IV. Heat sink over temperature.
  - V. Short circuit.
  - VI. Protection against lightning.
  - VII. Surge arrestors to protect against Surge voltage induced at output due to external source.
  - VIII. Any other protection in view of grid supply.
  - IX. Anti-Islanding Protection.
  - X. Fault ride-through feature.
- h) It should have a user-friendly LED/LCD display for programming and viewing online parameters such as:-
  - I. Inverter per phase Voltage, current, kW, kVA, and frequency,
  - II. Grid Voltage and frequency,
  - III. Inverter (Grid) on Line status,
  - IV. PV panel voltage,
  - V. Solar charge current and ambient temperature,
  - VI. Grid on
  - VII. inverter under voltage/over voltage
  - VIII. inverter overload
  - IX. inverter over temperature.
- i) The inverter shall have an arrangement for adjusting DC input current and should trip against sustained fault downstream and shall not start till the fault is rectified.
- j) The inverter shall be able to withstand an unbalanced load conforming to relevant IEC standards and Indian electricity conditions. The inverter shall include appropriate self-protective and self-diagnostic features to protect itself and the PV array from damage in the event of inverter component failure or from parameters- beyond the safe operating range due to internal or external causes. The self-protective features shall not allow signals from the inverter front panel to cause the inverter to be operated in a manner that may be unsafe or damaging. Faults due to malfunctioning within the inverter, including the commutation feature, shall be cleared by the inverter protective devices and not by the existing site utility grid service circuit breaker.
- k) The inverter shall go to shutdown/standby mode with its contacts open under the following conditions before attempting an automatic restart after an appropriate time delay.
- l) When the power available from the PV array is insufficient to supply the losses of the inverter,

the inverter shall go to standby/shutdown mode.

- m) The inverter control shall prevent excessive cycling of shut down during insufficient solar radiance.
- n) Operation outside the limits of power quality should cause the power conditioner to disconnect the grid. Additional parameters requiring automatic disconnection are
  - I. Neutral voltage displacement
  - II. Over current
  - III. Earth fault
  - IV. Reverse power
- o) In each of the above cases, tripping time should be sufficiently small to avoid damage to the inverter including all of its components and accessories.
- p) The Bidder shall provide data sheet for inverter along with their offer as per Guaranteed Technical Particular.
- q) Inverter shall be tested from the test centres / NABL / BIS / IEC accredited testing & calibration laboratories.

### **SECTION 3: ELECTRICAL WORKS**

#### **A. ARRAY JUNCTION BOXES/(DCDB):-**

- a) The junction box shall be dust-free, vermin, and waterproof for outdoor applications IP 65/66/67 and made of Thermoplastic / Polycarbonate material.
- b) **AJB/DCDB should be provided separately; the built-in AJB/DCDB with inverter will not be considered.**
- c) The terminal will be connected to copper bus-bar arrangement of proper size to be provided with terminal blocks should be housed in the junction box with suitable termination threads Conforming to IP65/66/67 standard. The junction boxes shall have suitable cable entry points fitted with cable glands of appropriate sizes for both incoming and outgoing cables.
- d) Suitable markings shall be provided on the bus-bars for easy identification and cable ferrules will be fitted at the cable termination points for identification.
- e) Each array junction Box will have suitable Reverse Blocking Diodes(2 Nos. Each) of maximum DC blocking voltage of minimum 600 V with suitable arrangement for its connecting.
- f) The array junction Box will also have the suitable surge protection device. The hinged door should be used with EPDM rubber gasket to prevent water entry.
- g) The junction Boxes shall have a suitable arrangement for the following (typical):-
  - I. Combine groups of modules into independent charging sub-arrays.
  - II. Provide arrangements for disconnection of each of the groups.
  - III. Provide a test point for each sub-group for quick fault location.
  - IV. To provide group array isolation.
  - V. The current carrying ratings of the junction Boxes shall be suitable with adequate safety factors, to interconnect the Solar PV system corresponding to 100 kWp.

## B. AC DISTRIBUTION BOARD (ACDB)

- a) The AC power output of the inverter shall be fed to the ACDB (metering panel & isolation panel) **which also houses energy meter**. The 4 UV AC output of the isolation panel shall be fed to the grid. AC energy is then synchronized with the grid and power is consumed by the grid.
- b) ACDBs must be floor-mounted with a civil/constructed base and have measuring instruments for all inputs and outputs, such as voltmeters, ammeters, frequency meters, and energy meters, to accurately measure deliverable units, kWh, and selector switches according to specifications.
- c) All the power cables shall be taken through the top/Bottom of the panel as per site requirements.
- d) The ACDB shall be fitted with a suitable rating & size copper bus, MCCB, indicators for all incomer and outgoing terminals, LED, and Multi-function meter to monitor & measure the power to be evacuated (per below diagram).
- e) Nuts & bolts and all metallic parts shall have to be adequately protected against the atmosphere and weather prevailing in the area.
- f) Modifications/additions if any, in the existing LT panel shall be done at the site for connection to the supply ACDB and covered in the scope of Bidder.

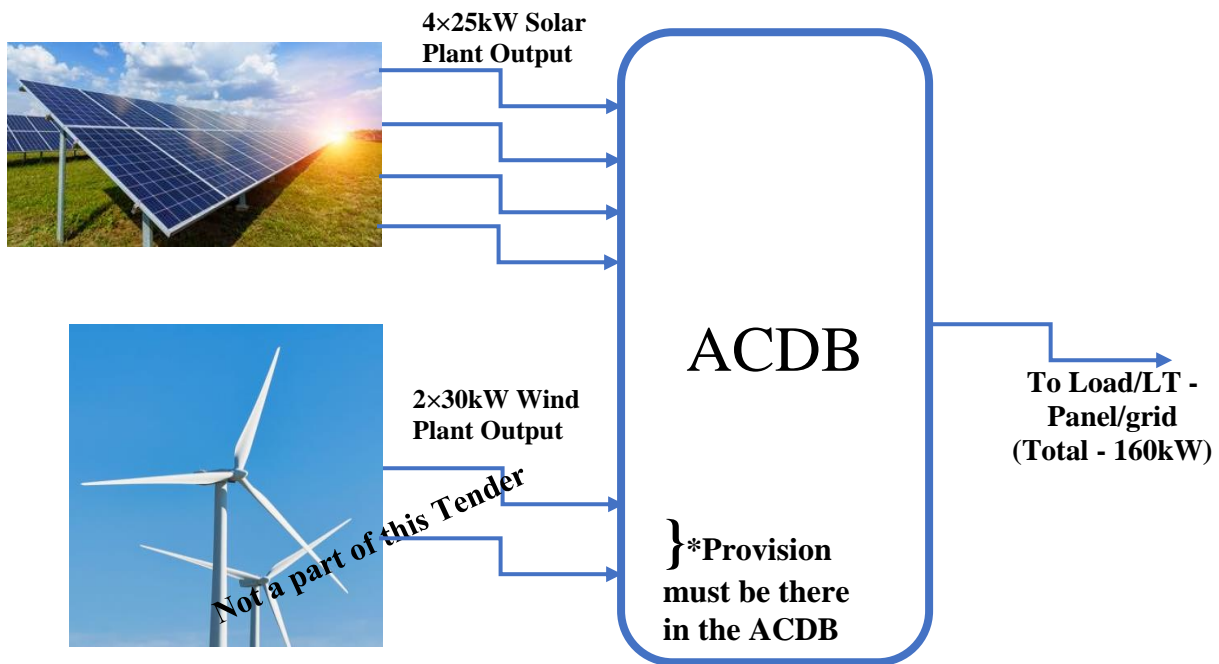

\*Note:-

1. The ACDB must be equipped to support the output of a 2x30kW wind plant in the near future.
2. There will be two separate connections of wind energy plants with an individual capacity of 30kW.



3. The required Bus bars and energy meters specified/for in the schematic must be supplied and will be included in this tender.
4. ACDB to load/LT panel/grid cable must be capable and designed, considering the schematic diagram above.
5. A separate tender/procurement will be used for the wind power plant and connection up until the ACDB; however, the solar plant installer's representative must be present when the wind plant is connected to the ACDB.

### **C. WIRING**

- a) All instruments and panel wiring shall be of heat-resisting and extinguishing type in compliance with IS. Plastic or porcelain cleats of the limited compression type shall be used for holding wiring runs. All wires shall be suitable for bending to meet the terminal studs at right angles. Metal cases of all apparatus mounted on panels shall be separately earthed.
- b) The underground cables of **considerable derating factors** to be used for power transmission from **Inverter** to **ACDB** to **LT Panel**.
- c) No hanging wires are permitted in any case.
- d) The wiring should be of high safety standards, considering continuous student movement in the areas.

### **D. CABLE ACCESSORIES**

- a) All the wires/cables (whatever if) should be of Copper, 4 core XLPE unless mentioned specifically.
- b) Only terminal cable Joints shall be accepted. No cable Joints to Join two cable ends shall be accepted.
- c) Cable terminations shall be made with suitable cable lugs & sockets etc., crimped properly and passed through brass compression type cable glands at the entry and exit point of the cubicles. The panels bottoms should be properly sealed to prevent entry of snakes/lizard etc. inside the panel.
- d) The terminal end of cables and wires are to be fitted with good quality numbered ferrules of proper sizes so that the cables can be identified easily.
- e) All the wires/cables should be properly hinged (No hanging wire is permissible).

### **E. EARTHING**

- a) Earthing should be in accordance with the total power capacity of the plant i.e. 100Kw.
- b) Each array structure of the SPV shall be earthed properly. The array structure are to be connected to earth pits as per Industrial standard. Junction boxes shall be connected to the main Earthing conductor/ electrode.
- c) Earthing system installation shall be in strict accordance with the Indian Electricity Act 2003 upto date.
- d) There should be separate Earthings for AC and DC systems and each contains **a pair of parallel** connection setup. The depth of earthing rods will be per soil condition and calculations.

- e) The earthing strips (AC, DC & LA) should be welded/double bolted, for extension/connections.
- f) **Necessary Test Point provision shall be made for bolted isolating joints of each Earthing pit for periodic checking of earth resistance.**
- g) Earth resistance of the earth pits shall be tested in the presence of the representative of Principal Investigator or Nominee.

#### **F. LIGHTNING (LA) & OVER-VOLTAGE PROTECTION**

- a) L.A. should be in accordance with the total power capacity of the plant i.e. 100kW and its coverage area.
- b) The PV Power Plant should be provided with Lightning Arrester and over-voltage protection connected to the proper earth system. The main aim of overvoltage protection is to reduce the overvoltage to a tolerable level before it reaches the PV or other sub-system components. The source of overvoltage can be lightning or other atmospheric disturbances.
- c) The lightning system / Conductors shall be made as per applicable Indian industrial standards.
- d) Two Nos. of Earthing strips connected in parallel to be used for the LA separately.

#### **G. POWER CABLING (refer SLD diagram)**

- a) The power cables shall be XLPE insulated, PVC outer sheathed aluminum conductor, and armored cables rated for 1100 V grade. The power cables shall be of 4 cores for sizes roundoff 35 sq. mm for each 3 phase 25kW AC load. Where high-voltage equipment is to be fed, the cables shall be rated for continuous operation at the voltages to suit the same.
- b) Power cables feeding load/LT panels shall be of sizes as per calculations or indicated in the tender specifications. In all other cases, the sizes shall be as approved by the Principal Investigator or nominee, after taking into consideration the load, the length of cabling, and the type of load. (the calculation should firmly submit to the Principal Investigator or its nominee)

**H. Inverter mount and Shading:** Inverters should be properly mounted and shaded per Company/Industry standard and guidelines. The mounting structure material should be GI of the same grade as solar mounting structure.

## TECHNICAL SPECIFICATIONS OF MAJOR EQUIPMENTS

<b>1.1 SPECIFICATION FOR SOLAR PV PANEL</b>			
<b>SL No.</b>	<b>Description</b>	<b>As Per NIT</b>	<b>As Per NIT</b>
1	Minimum. Output (Pmax) as per STC	<b>500Wp-550Wp MONO-PERC monofacial</b>	<b>650-715W TOPcon Bifacial</b>
2	Voc/Isc	45V/13A or higher	47/17 or higher
3	MPP Voltage (Vmpp) V	40V (min)	45V (min)
4	MPP current (Imp) A	12A (min)	14.5 (min)
5	Open circuit voltage (Voc)V	45 V (min)	47 (min)
6	Normal operating cell temperature	45 ± 2 Degree C	45 ± 2 Degree C
7	Module dimensions (LxWxH)	As per rating of the panel	As per rating of the panel
8	PV Module type	Mono Crystalline (High eff.)	TOPcon (High Efficiency)
9	No. of PV cells per Module	144/As per Manufacturer Standard	132/144/As per Manufacturer Standard
10	Min. efficiency of solar cell	> 20.5 %	>22.5%
11	Solar module frame material	Aluminium	Aluminium
12	Weather resistant junction	IP65 and above	IP67 and above
13	Glass	Toughened / Tempered	Toughened / Tempered
14	Glass iron content	Low Iron	Low Iron
15	glass transmissivity	High transmissivity	High transmissivity
16	Frame	Anodized aluminium	Anodized aluminium Alloy
17	Encapsulation	PID Free and UV-resistant	PID Free and UV-resistant
18	Trilaminate back surface	Tedlar / Polyester	Low iron printed Semi tempered glass
19	By-pass diode	2Nos. in each module	2Nos. in each module
20	Standard	IEC 61215 / IS 14286 & IEC 61730 Part 1 & Part 2	IEC 61215 / IS 14286 & IEC 61730 Part 1 & Part 2
21	Performance Guarantee	10 years of 90% power output 27 years of 80% power output	12 years of 94% power output 30 years of 85% power output
22	Product Warranty	10 years against manufacturing defects.	10 years against manufacturing defects.
23	PV Panel certification	TUV/NISE	TUV/NISE
24	Made	Solar PV modules/Panels are to be of Indian origin (Cells of the panel may be overseas made).	Solar PV modules/Panels are to be of Indian origin (Cells of the panel may be overseas made).
*Failure to satisfy clause 4(f) of section 1 of the technical specification; testing of 10% random samples will be witnessed by IIT Kanpur, and the vendor shall bear all costs.			

--

<b>1.2 SPECIFICATION OF SOLAR INVERTER (GRID connected)</b>		
<b>SL No.</b>	<b>Description</b>	<b>As Per NIT</b>
1	Type	Grid connected, PID Enabled
2	Max. DC Array Input Voltage	1000 V (Preferable)
3	DC voltage tolerance	20% to +15% of the DC array input voltage
4	Type of inverter	<b>Dual MPPT (with Multiple string inputs)</b>
5	Switching Device	MOSFET / IGBT BASED
6	Continuous inverter output rating	25 kWp (as per requirement of location)
7	Output wave form	Pure Sine wave output
8	Total harmonic distortion	< 5% with rectifier load
9	Nominal AC output voltage and frequency	415V 3 phase 50Hz, 50 Hz +0.5 Hz
10	Output frequency	50Hz
11	Grid frequency tolerance	+5%
12	Grid frequency synchronization range	3Hz
13	THD	<3% with resistive
13	No-Load losses	<1%
14	Power factor	> 0.9 Lagging
15	Inverter efficiency	>98 % at nominal voltage & power
16	Noise level	< 57 db
17	Certifications	IEC 61727, CE, IEC 62109-1, IEC 62109-2, IEC 61683/IS 61683, IEC 60068-2(1,2,14,30)
18	Idle current	< 4 % of rated capacity
19	Regulation Line regulation and load regulation	-2%
20	Over load features	150% for 1 minute , 110-120% for longer time
21	Cooling	Forced air cooling with temperature controlled cooling/Regulated air cooling
22	Operating Temperature	(-)10°C to 55°C
23	Relative Humidity	0.95
24	LED/LCD display	Indications display shall indicate system functional parameters and protection functional indicators
25	Data Monitor and display controls	RS 485, Ethernet connectivity/Wi-Fi
26	Protections	1) Input over Voltage 2) Low/High frequency 3) Short Circuit 4) Under/over output voltage 5) Over Temperature 6) Grid input under voltage/over voltage with auto recovery 7) DC disconnect device 8) DC reverse polarity 9) Anti Islanding protection as per the standard 10) Fault ride through feature

27	Enclosure Protection Safety	IP65 and above
28	Warranty	5 years or more.

<b>1.3</b>	<b>SPECIFICATIONS FOR ARRAY JUNCTION BOX (DCDB)</b>	
------------	---	--

Sl. No	Description	As per NIT
1	No. of modules in series	As per NIT
2	No. of modules in parallel	as per manufacturer standard 500Wp -550Wp
3	Minimum Capacity of each SPV panel	MCB / MCCB
4	Switch gears	1.1 KV grade 100 Amps capacity
5	Connectors	FRLS copper conductor single-core cable
6	Wiring	1.1 KV grade of required size.
7	Enclosure Protection	IP 65/66/67 (outdoor) dust & vermin proof weather resistance
8	Enclosure	Thermoplastic / Polycarbonate material
9	Size	As per manufacturer standard/ Site requirement.

<b>1.4</b>	<b>SPECIFICATIONS FOR PV PANEL SUPPORT STRUCTURE</b>	
------------	--	--

Sl.No.	Description	As per NIT
1	Material	Hot dip galvanized steel (85 Microns) with corrosion less paint.
2	Thickness of member	2 mm
3	Over all dimensions	As per manufacturer standard
4	Wind rating	180Km/H
5	Tilt angle and adjustment	per site requirement (around 21 to 25 Degree)
6	Peach of structure	
7	Hard wears & fastener	SS 304. ( 1 bolt+2 plain washer+ 1 spring washer+ 1 nut)
8	Foundation	To be approved by the Principal Investigator or Nominee based on the STAAD analysis report

<b>1.5</b>	<b>SPECIFICATIONS FOR ACDB (AC PANEL)</b>	
------------	---	--

SL.No	Description	As per NIT
1	Make	As per approved make list
2	Thickness of sheet metal	2 mm
3	Size of bus bar	25mmX5mm <b>copper or more (per calculation)</b>
4	Material of bus bar	<b>Copper</b>
5	Bus bar Insulation	PVC Sleeve

6	Over all dimension	As per design
7	Degree of protection	IP 65/66/67 as per IS 13947

**Tender drawings**

<b>Drg. No.</b>	<b>Title</b>
01	SITE PHOTOGRAPHS and PLAN
02	STANDARD SINGLE LINE DIAGRAM (SLD)



**Plan:**

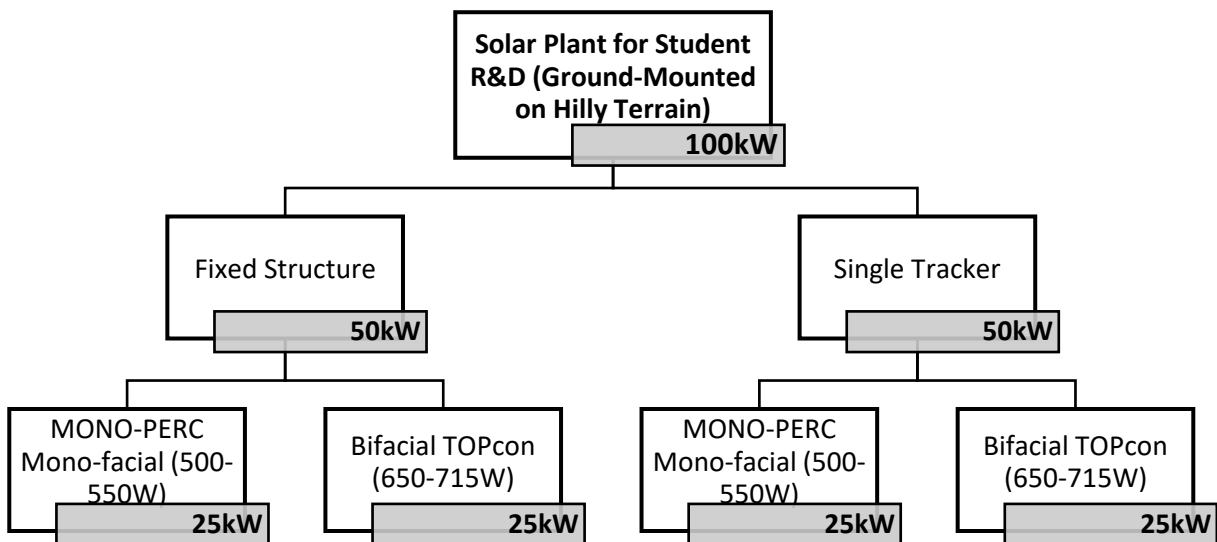

## 02) Standard SLD:

### Standard SLD of Solar plant setup

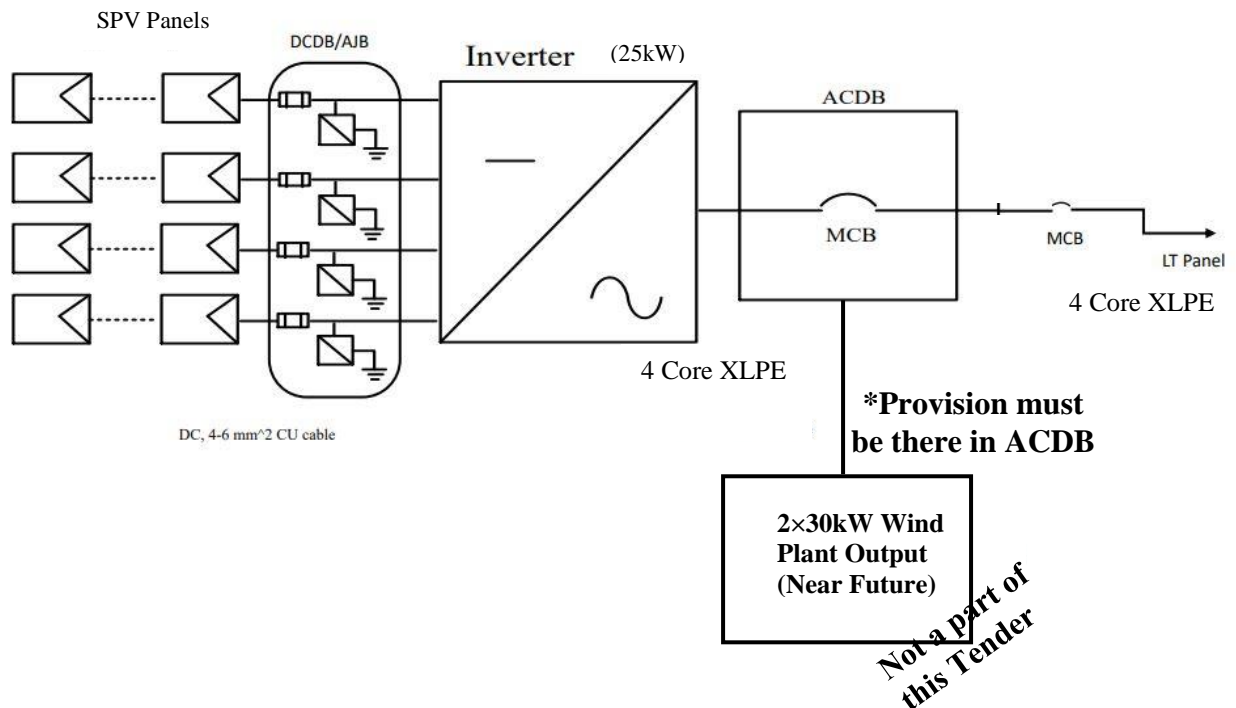

Note:-

1. This SLD is standard for all and may be subjected to any changes as per site requirement.
2. All the DC Connections shall be done by Standard DC cables (+ve, -ve, and E) with a suitable thickness mentioned in the SLD.
3. All the AC Connections shall be done by Standard AC cables (3 phase R, Y, B, N, E) with a suitable thickness mentioned in the SLD.
4. Connection to the LT panel will be done by the Standard AC cables (3 phase R, Y, B, N, E) with a suitable thickness mentioned in the SLD.
5. *At Location:* The LT panel is at the ground floor of a building block (Length of the cable should be from the plant to the LT panel with suitable wiring procedure as per the institute (IWD) guideline. (In case, a Separate MCCB need to be installed by the vendor at the incomer, without any extra cost/charges).
6. Derating and other loss factor of cables should be considerable.
7. Reference to the Inverters are supplied through Standard AC cables as per their ratings.
8. No hanging wire is allowed, all the wire of the plant should be properly hinged/covered/trayed.

9. All the cables AC/DC/Earthing should be in proper cable trays.

10. All the equipment's need to verified by the PI or Nominee.

**\*\* The drawings, SLD and reports are tentative, may subjected to slight changes, the final approval of the same may be given after the site visit. \*\***



## **MAINTENANCE DURING DEFECT LIABILITY PERIOD (DLP)**

- a) The system will be comprehensively maintained by the contractor with no extra cost for Five (5) years from the date of taking over by the department i.e. during warranty / guaranty period.
- b) **Solar PV panels and Inverters is/will be covered in OEM warranty through the Vendor/OEM, remaining all the equipment, faults, and workmanship will be in the scope of work during the DLP.**
- c) The contractor has to depute an experienced service engineer to check the complete installations on a regular basis or as and when required for Five (5) years from the date of taking over of the installations by the department i.e. during warranty/guarantee period, for which nothing extra shall be paid.
- d) Immediate fault rectification on lodging of complaint. The fault rectification shall be carried out by skilled staff. All fault rectification shall be done within reasonable time preferably within **36 hrs** and all faulty equipment shall be collected from site and repaired equipment delivered at the site.
- e) Maintenance will also include:-
  - a. Providing on-call services for any breakdown and rectification of fault within 24 hours of the reporting of the problem.
  - b. Any delay in attending the complaints beyond 36 hours of lodging complaint will attract a penalty of Rs. **1000/-** per day, this charges will be deducted/managed from security money.
  - c. The maintenance service provided shall ensure proper functioning of the SPV system as a whole to the extent covered in the contract. All preventive /routine maintenance and breakdown/corrective maintenance required for ensuring maximum uptime shall have to be provided.
  - d. The bidder shall submit the preventive/Routine/breakdown maintenance schedule as per their standard practice along with the bid. During warranty period of *10 years for PV modules*, contractor shall check / inspect the complete system once every year in the month of March and submit the detail report of working of the system.

**Note-** Equivalent standards may be used for different system components of the plants. In case of clarification following person/agencies may be contacted.

- Ministry of New and Renewable Energy (Govt. of India)
- National Institute of Solar Energy
- The Energy & Resources Institute
- TUV Rheinland
- UL

### LIST OF APROVED MAKES

1.	SOLAR PV PANEL	WAAREE, VIKRAM, ADANI, TATA SOLAR, LUMINIOUS
2.	GRID TIE INVERTER	WAAREE, ABB/FIMER, DELTA, SMA, SCHNEIDER,
3.	CONDUIT PIPE PAINTED INSIDE & OUTSIDE 16 SWG ISI MARKED.	BEC, M-KAY, AKG, S.K. (E.R.W.)
4.	CONDUIT ACCESSORIES & JUNCTION BOXES	<ul style="list-style-type: none"> <li>• ALL MADE OUT OF 16G MS SHEET</li> <li>• ALL MADE OUT OF 14G MS SHEET</li> </ul>
5.	WIRES PVC INSULATED AND PVC SHEATHED FR/ FRLS /CONTROL WIRES (IS MARKED)	FINOLEX, HAVELLS, R.R. KABEL. KEI, GLOSTER, V-GUARD, POLYCAB
6.	PVC/XLPE INSULATED LT CABLES	UNIVERSAL , GLOSTER , KEI, HAVELLS , POLYCAB
7.	XLPE INSULATED HT CABLES	UNIVERSAL , GLOSTER , KEI, HAVELLS, POLYCAB
8.	MODULAR SWITCHES AND SOCKETS	LEGRAND (ARTEOR),ABB, L&T, MK HONEYWELL
9.	FLUSH TYPE SWITCH AND SOCKETS	ANCHOR, KINJAL, SSK, HAVELLS REO
10	AIR CIRCUIT BREAKER	L&T, ABB, SIEMENS,C & S
10	FUSE SWITCHES UNIT/SWITCH FUSE UNIT & HRC FUSES	L&T, SIEMENS, HAVELLS,C & S
11	DISTRIBUTION BOARDS MCB	LEGRAND, L&T, ABB, SIEMENS,C & S
12	LOOSE WIRE BOX FOR DISTRIBUTION BOARDS	LEGRAND, L&T, ABB, SIEMENS,C & S
13	MCB'S	LEGRAND, L&T, ABB, SIEMENS,C & S
14	MCCB	LEGRAND, L&T, ABB, SIEMENS,C & S
15	CABLE LUG	ASCON (HEAVY GAUGE), JAINSON, DOWELS
16	SAFE TRIP/RCCB/ELCB	LEGRAND, L&T, ABB, SIEMENS,C & S
17	GI PIPE 'B' CLASS	PRAKASH, SURYA, JINDAL
18	ELECTRICAL SWITCHBOARDS / FEEDER PILLAR/LT PANEL/ACDB PANEL	MILESTONE SWITCHGEAR PVT. LTD NEPTUNE SYSTEMS PVT. LTD. TRICOLITE ELECTRICAL INDUSTRIES MODERN SWITCHGEARS/ ESSAAR/ADLEC
19	TELEPHONE WIRES/TELEPHONE CABLES / JELLY FILLED TELEPHONE CABLES	FINOLEX, DELTON, HAVELL'S, R.R. KABEL
20	TELEPHONE TAG BLOCKS	KRONE, POUYET
21	TELEPHONE OUTLET	MK ELECTRIC, LEGRAND (MOAIC), CRABTREE (PICCADILLY)
22	GI RACEWAYS	MILESTONE ENGINEERING, LEGRAND, MDS NEPTUNE SYSTEMS PVT. LTD., MK
23	PVC RACEWAYS	LEGRAND, MK
24	PANEL METERS	L&T RISHAB, AE, SECURE, CONZERV, C&S
25	CURRENT TRANSFORMER	GILBERT MAXWELL, KAPPA, AE
26	SELECTOR SWITCH	L&T, KAYCEE, SIEMENS, C&S
27	PROTECTIVE RELAYS	ABB, C&S
28	SMART ENERGY METER	ENERCON , ANCHOR , L&T, HPL, CONZERV, SECURE
29	CHANGEOVER SWITCH	L&T, HPL, HAVELLS, C&S
30	ELECTRONIC BALLAST	PHILIPS, WIPRO, BAJAJ, DECON, CROMPTON, HAVELLS

31	DLP PLASTIC TRUNKING	LEGRAND, MK
32	PROGRAMMABLE LOGIC CONTROLLER(PLC)	SIEMENS, ALLEN-BRADLEY, SCHNEIDER
33	EARTHING (CHEMICAL EARTHING) PLATE EARTHING	JMV, AS PER CPWD NORMS
34	CONTROL RELAY PANEL	CGL, SCHNEIDER, ABB
35	LIGHTNING ARRESTOR	ABB, ALLTEC, JMV

**LIST OF APPROVED MAKE FOR CIVIL AND PLUMBING WORK**

Sr. No	Item	Approved Make
1.	ORDINARY PORTLAND CEMENT	AMBUJA, ULTRATECH, JAYPEE,
2.	WHITE CEMENT	BIRLA, J.K
3.	<b>TMT FE -500/415</b>	<b>TATA, SAIL, RINL (VIZAG), JSW, ESSAR STEEL, SANGHI, ELECTROTHERM STEEL, JINDAL STEEL</b>
4	PAINT, PRIMER	ASIAN, BERGER, ICI,
5	PUTTY	BIRLA , BERGER, ASIAN
6	POLISH	MRF, ASIAN, ICI, TARALAC
7	WATER STOPS	ARTI CABLES, FIXOPAN
8	ALUMINUM SECTIONS	JINDAL, HINDALCO , GUJARAT EXTRUSION, BANCO
9	ALUMINUM FINISH	COLOR ANODIZED / PURE POLYESTER POWDER COATING
10	RUST REMOVER	FEOVERT (KRISHNA CONCHEM), ROFF RUST CLEAR (PIDILITE INDUSTRIES)
11	POLYMER BONDING AGENT	MONOBOND (KRISHNA CONCHEM), ROFF BOND REPAIR (PIDILITE INDUSTRIES)
12	SUPER PLASTICIZER FOR JACKETING	SUPERCON-100 (KRISHNA CONCHEM), ROFFPLAST 330 / CONCRETE MASTER
13	REBAR AND ANCHOR FASTENERS	HILTI OR FISCHER OR MUNGO.
14	ACRYLIC SBR BASE BONDING AGENT	MONO-BOND SBR (KRISHNA CONCHEM), CICO, BASF, PIDILITE
15	EPOXY BONDING	EPI BOND 21 LP (KRISHNA CONCHEM), ROFF CONCRETE BOND (PIDILITE)
16	PVC SLEEVE	SUPREME / ASTRAL / PRINCE
17	EXPANSION BOARD	CAPCELL HD BOARD
18	EXPANSION JOINT	PIDILITE / ROOF/ LATICRETE
19	EXPANSION JOINT SYSTEM	3R AS PER ITEM DESCRIPTION
20	WATER PROOFING	BASF/ FOSROC / SIKA , PIDILITE
21	OVERDECK INSULATION	BASF/ FOSROC / SIKA , PIDILITE
22	SWR PVC PIPE & FITTINGS 6 KG CM <sup>2</sup> ; FITTINGS : 6 KG CM <sup>2</sup> ECO. DRAIN PIPE & FITTINGS	FINOLEX /SUPREME/PRINCE/ SUPREME/ ASTRAL
23	GULLY TRAP	GIRCO / TIRUMALA / SONIA/ SUPREME/ ASTRAL
24	STONE WARE PIPES FOR INTERNAL UNDER GROUND	GIRCO / TIRUMALA / SONIA

	DRAIN PIPE	
25	RCC HUME PIPES EXTERNAL MAIN UNDER GROUND PIPE	INDIAN HUME PIPE / PRANALI
26	C.I. PIPE & FITTINGS	NECO OR EQ.
27	PPR PIPES & PPR FITTINGS	SUREME/PRINCE
28	M.S/G.I. PIPES FOR WATER SUPPLY	TATA / JINDAL/ SWASTIK
29	ASTM/CPVC PIPE & FITTINGS FOR WATER SUPPLY	ASTRAL / SUPREME/ASHIRWAD
30	COMPOSITE PLUMBING PIPE & COMPOSITE FITTINGS	KITEC OR EQ.
31	G.I. PIPES FITTINGS WATER SUPPLY	DRP-M / R-BRAND / ZOLOTO
32	GI TO GI JOINTS	CHAMPION / EQUIVALENT
33	SOLVENT CEMENT	SUPREME / KISSAN / FINOLEX
34	BALL VALVES	LEADER / ZOLOTO / AUDCO
35	WHEEL VALVES	LEADER / ZOLOTO/AUDCO
36	DCV / NRV	ZOLOTO/SPIREX/AUDCO
37	TAR	SHALIBIND / TIKIBOND-BS
38	SELF PRIMING SEWAGE PUMPS	HBD / GRUNDFOS
39	VALVES	AUDCO/ZOLOTO / R.B. / KBL / KSB
40	PUMPS	CROMPTON/ KIRLOSKER / MAHINDRA
41	STARTER	SIEMENS / L&T

*Note: Principal Investigator or Nominee shall approve any other material that are not listed here.*

#### **Requirement of Technical Representative(S) and recovery Rate -**

Sl. No	Minimum Qualification of Technical Representative	Discipline	Designation (Principal Technical / Technical representative)	Minimum Experience	Number	Rate at which recovery shall be made from the contractor in the event of not fulfilling this criteria.	
						Figures	Words
1.	B.E./B.Tech	Electrical / mechanical	Project Manager/ Site Engineer	5	1	Rs.25,000/- p.m	Twenty Five Thousand per month

\*For supervision of solar PV installation as well as electrical items of work, technical representatives of the respective disciplines will be required to be deployed.

## QUALITY ASSURANCE OF THE WORK

### **Sampling of Materials:**

1. The contractor shall procure all the materials at least in advance so that there is sufficient time to testing and approving of the materials and clearance of the same before use in work.
2. All materials brought by the contractor for use in the work shall be got checked from the Engineer-in-Charge or his authorized representative of the work on receipt of the same at site before use.
3. The contractor shall be fully responsible for the safe custody of the materials issued to him even if the materials are in double lock and key system.
4. There shall be pre dispatch factory inspection for all major equipment's like Solar PV Panels and Grid tied inverters. The solar PV Panels shall be TUV/NISE Certified. The sample of Solar PV panel shall be tested at TUV/NISE labs.
5. The testing charges shall be borne by the bidder.
6. The work shall be treated as on works contract basis and the rates tendered shall be for complete item of work and all charges for items contingent to the work, such as packing, forwarding, insurance, freight, testing charges of sample solar PV panel at TUV/NISE lab and delivery at site for the materials to be supplied by the contractor, watch and ward of all materials at the site, labour related expenses as per relevant labour laws, testing of materials/ samples etc.
7. The Panel mounting structure design report shall have to be done by the executing agency as per the indicated layout in the attached drawing. The overall load on the terrace shall not to be exceeded by 180 kg/m<sup>2</sup>. The proposed design shall be got approved by the IIT Kanpur before execution by the agency.
8. ***The Solar PV modules shall be handled with care during the course of installation work, any damage caused to the modules shall be made good by the contractor at his own cost.***
9. Some restrictions may be imposed by the security staff etc. on the working and for movement of labour, materials, etc. The contractor shall be bound to follow all such restrictions/instructions and nothing extra shall be payable on account of the same.
10. It should be noted that licensed/competent welders, fitters, masons, and electricians shall only be allowed for the piping, civil, and electrical works. (as per govt. norms)
11. The contractor shall fully comply with all legal orders and directions of the Public or local authorities or municipality abide by their rules and regulations and pay all fees and charges for which he may be liable in this regard. Nothing extra shall be paid/reimbursed for the same.
12. The structural and architectural drawings shall at all times be properly co-related before executing any work. However, in case of any discrepancy in the item given in the schedule of quantities appended with the tender and Architectural drawings relating to the relevant item, the former shall prevail unless otherwise given in writing by the Principal Investigator.
13. Any trenching and digging for laying sewer lines/water lines/cables etc. shall be commenced by the contractor only when all men, machinery's, and materials have been arranged and closing of the trench(s) thereafter shall be ensured within the least possible time. All the excavation and digging of the trenches shall be done manually as numbers of service lines are passing inside the campus except in certain cases as approved by PI. No Hydraulic Excavator shall be allowed for earth digging work except in certain cases as approved by PI.
14. It shall be ensured by the contractor that no electric live wire is left exposed or unattended to avoid any accidents in this regard.

15. The entire royalty at the prevalent rates shall have to be paid by the contractor on all the boulders, metals, shingle sand etc. collected by him for execution of the work, directly to the Revenue authority or authorized agents of the State Government concerned or the Central Government, as the case may be.
16. The contractor shall bear all incidental charges for cartage, storage and safe custody of materials issued by the departments and shall construct suitable go downs, yards at the site of work for storing all materials as to be safe against damage by sun, rain, dampness, fire, theft etc. at his own cost and also employ necessary watch and ward establishment for the purpose, at his own cost. Materials to be charged directly to work and stipulated for issue free of cost shall also be issued to the contractor as soon as those are received at site or at the stipulated place of issue.
17. The scope of contract comprises the supply, installation, testing & commissioning of 100 kW capacity rooftop on grid type solar PV plant on the GI mounted structure at the campus of Sindhu Central University (SCU) - Khalatse, Ladakh, with **5 years** of defect liability. The provision of all labour, materials, construction of plant equipment and transpiration, temporary works, and everything, whether of temporary or permanent nature required in and for such construction, completion, and maintenance so far as the necessity for providing the same is specified in or reasonably be inferred from the contract. The contractor shall make his own arrangements for the store/storage of materials, accommodation for his staff, etc., and no claim for the temporary accommodation from the contractor shall be entertained.
18. The contractor shall carry out and complete the said work in every respect in accordance with this contract and as per the directions and to the satisfaction of the PI. Issue of further drawings and /or written instructions, detailed directions, and explanations which are hereinafter collectively referred to as instructions of the PI in regards to:-
  - a. The variation or modification of the design, quality, or quantity of works or the addition or omission or substitution of any work.
  - b. Any discrepancy in the drawings or between the schedule of quantities and /or drawings and/or specifications.
  - c. The removal from the site of any materials brought thereon by the contractor and the substitution of any other material thereof.
  - d. The dismissal from the works of any persons employed thereupon.
  - e. The opening up for inspection of any work covered up.
  - f. The amending /making good of any defects.
19. Water and electricity required for the works shall be supplied free of charge.
20. **Conditions for Electrical Works:-**
  - a. All chase cuttings in the wall, for recessed conduits & boxes and drilling the holes shall be done with power-operated machines only. No chase shall be allowed to be cut manually with the use of a hammer & chisel.
  - b. All cuttings in cement plaster and brick shall be made good by using cement mortar **1:3** (1 part cement, 3 part coarse sand).
  - c. The cut surfaces shall be repaired by an experienced mason only to match the repaired plaster with the original.
  - d. All such repaired surfaces shall be cured for 3 to 4 days to keep the surfaces wet, using water spray machine (hand/motor operated) and avoid unnecessary flooding of the area.

## 21. Payment shall be regulated as under-

<i>Estimated cost of the work: 48,00,000/ (Incl. of all Taxes)</i>	<i>Earnest Money: 1,00,000/</i>
--	---------------------------------

- a. **75%** of the tendered rate on receipt of materials at the site.
  - b. **12.5%** of the tendered rate on successful installation and Commissioning.
  - c. **10%** of the tendered rate on Testing, and satisfactory performance reports of at least one month.
  - d. The corresponding deducted security (**2.5%**) from the total completed cost item wise, shall be retained by IIT Kanpur till the completion of the comprehensive warranty of the major equipment/completion of the defect liability period of **5** years or it may be released against the Bank Guarantee of same amount for the above said period.
22. The earnest money of the unsuccessful tenderers shall be refunded on written request, within 1(one) month of the award of work. The earnest money of the successful tenderer shall however be adjusted towards the security deposit.
23. The following drawings shall be provided by the contractor **before execution** of the above work-
- a) Solar PV plant detailed equipment layout, Solar PV array layout with mounting structure on the terrace, STAAD analysis of the mounting structure to withstand wind speed of 180kmph or higher, single line diagram, Communication architecture, cable schedule, earthing detailed drawing, lightning arrestor calculation and drawing & electrical connection drawings showing details of size, type, and mode of installation.
  - b) GFC for 100 kW solar PV plant showing inverter detail, ACDB panel connection, Earthing, and LA connection.

### **Completion drawings (As-built):-**

- a. On completion of works and before issuance of the completion certificate, the contractor submits completion drawings in the form of four complete sets of originals (reproducible) in hardcopy and softcopy.
- b. As built GA and schematic layout drawings of solar PV plant detailed equipment layout, Solar PV array mounting structure on the terrace, STAAD analysis of the mounting structure to withstand **wind speed of 180kmph** or higher, single line diagram, Communication architecture, cable schedule, Earthing detailed drawing, lightning arrestor calculation and drawing & electrical connection drawings showing details of size, type, and mode of installation.
- c. Technical literature, TUV/NISE solar PV panel, inverter test certificates, and operation and maintenance manuals for inverters.

## 24. Scope of Works and Special Conditions

Scope of work includes Design, supply, installation, commissioning & Testing of Solar PV panels, grid tied inverters, equipment and materials, testing at manufacturers works, inspection, packing and forwarding, unloading at site, associated civil works, services, permit and incidentals, defect liability period of 5 years at all stages of 100 kWp Grid connected Solar PV plant at The “Sindhu Central University (SCU)” - Khalatse, Ladakh, India. Solar PV modules

in array including mounting frames, structures, foundation for holding structures and module, inter connection etc.

- a) Array junction boxes, distribution boxes / boards and fuse boxes, MCBs, Surge Arrestors, isolation system etc.
- b) Solar Inverters, / Data logger inbuilt with inverter to check the generated data.
- c) Digital Voltage meter and Ammeter, smart Kwh Meters. Metering instrument and protection relays.
- d) LT Power and control cables including end terminations and other required accessories for both AC & DC power.
- e) Lightening arrestors for lightning protection.
- f) Tool kit and Earthing kit.
- g) Suitable Earthing system with necessary earthing strips as per industry standards specification, for PV Array, DC power system, lightening protection system and for AC Panel.
- h) Covered enclosure made of suitable material for protection of wiring from PV Module to AIB and AIB to inverter.
- i) In addition to above, the bidder is required to measure the Solar Radiation and other climatic conditions. The major categories of site-specific assessment required are:-
  - Global Solar Radiation (GSR).
  - Diffuse Solar Radiation (DSR).
  - Sunshine Duration.
  - Atmospheric Turbidity.
  - Temperature & Humidity.
  - Wind Speed.
  - Dead load of Snow in Peak Seasons.
- j) Galvanized steel rigid/flexible conduits and accessories, Hume pipes, ferrules, lugs, glands, terminal blocks, galvanized sheet steel junction boxes, cable fixing clamps, nuts, and bolts, etc. as required.
- k) Civil works shall be performed concerning the Design and construction of self-supported module mounting structures with modules and for Inverters, panels, etc.
- l) Any other items not specifically mentioned in the specification but which are required for erection, testing, commissioning, and satisfactory operation of the solar power plant are deemed to be included in the scope of the specification unless specifically excluded on a Trunkey basis.
- m) Various supplies to meet out load: grid supply: 3 phase, 415 volts ac, Priority of utilization of solar plant generation for load.

Note: Solar plant shall be connected & synchronized to the existing grid directly and the generated load shall be supplied to a local distribution system.

25. The tender document contains 54 pages. No page of the tender document shall be removed, mutilated, detached, or cancelled.



## **SPECIAL CONDITION FOR SAFETY AT THE WORK SITE**

The contractor will identify one of the supervisors for taking care of implementation of Safety systems. The Contractor should follow the following General Guidelines governing the safety rules as laid down under:

1. Smoking is strictly prohibited at workplace.
2. Nobody is allowed to work without wearing safety helmet. Chinstrap of safety helmet shall be always on. Drivers, helpers and operators are no exception.
3. No one is allowed to work at or more than three meters height without wearing safety belt and anchoring the lanyard of safety belt to firm support preferably at shoulder level.
4. No one is allowed to work without adequate foot protection.
5. Usage of eye protection equipment shall be ensured when workmen are engaged for grinding, chipping, welding and gas-cutting. For other jobs as and when site safety co-coordinator insists eye protection has to be provided.
6. All safety appliances like Safety shoes, Safety gloves, Safety helmet, Safety belt, Safety goggles etc. shall be arranged before starting the job.
7. All excavated pits shall be barricaded & barricading to be maintained till the backfilling is done. Safe approach to be ensured into every excavation.
8. Adequate illumination at workplace shall be ensured before starting the job at night.
9. All the dangerous moving parts of the portable / fixed machinery being used shall be adequately guarded.
10. Ladders being used at site shall be adequately secured at bottom and top. Ladders shall not be used as work platforms.
11. Material shall not be thrown from the height. If required, the area shall be barricaded and one person shall be posted outside the barricading for preventing the tre-passers from entering the area.
12. Other than electricians no one is allowed to carry out electrical connections, repairs on electrical equipment or other jobs related thereto.
13. All electrical connections shall be made using 3 or 5 core cables, having a earth wire.
14. Inserting of bare wires for tapping the power from electrical sockets is completely prohibited.
15. A tools and tackles inspection register must be maintained and updated regularly.

16. Debris, scrap and other materials to be cleared from time to time from the workplace and at the time of closing of work every day.
17. All the unsafe conditions, unsafe acts identified by contractors, reported by site supervisors and / or safety personnel to be corrected on priority basis.
18. No children shall be allowed to enter the workplace.
19. All the lifting tools and tackles shall be stored properly when not in use.
20. Clamps shall be used on Return cables to ensure proper earthing for welding works.
21. Return cables shall be used for earthing.
22. All the pressure gauges used in the gas-cutting apparatus shall be in good working condition.
23. Proper eye-washing facilities shall be made in areas where chemicals are handled.
24. Connectors and hose clamps are used for making welding hose connections.
25. All underground cables for supplying construction power shall be routed using conduit pipes.
26. Spill trays shall be used to contain the oil spills while transferring/storing them.
27. Tapping of power by cutting electric cables in between must be avoided. Proper junction boxes must be used.

Principal Investigator

**Appendix -1**

**TENDER ACCEPTANCE LETTER**  
**(To be given on Company Letter Head)**

Date: \_\_\_\_\_

To,

\_\_\_\_\_  
\_\_\_\_\_  
\_\_\_\_\_

Sub: Acceptance of Terms & Conditions of Tender.

Tender Reference No: \_\_\_\_\_

Name of Tender / Work: - \_\_\_\_\_

Dear Sir,

1. I / We have downloaded / obtained the tender document(s) for the above mentioned 'Tender/Work' from the web site(s) namely: \_\_\_\_\_ as per your advertisement, given in the above mentioned website(s).
2. I / We hereby certify that I / we have read the entire terms and conditions of the tender documents from Page No. \_\_\_\_\_ to \_\_\_\_\_ (including all documents like annexure(s), schedule(s), etc ..), which form part of the contract agreement and I / we shall abide hereby by the terms / conditions / clauses contained therein.
3. The corrigendum(s) issued from time to time by your department/ organisation too have also been taken into consideration, while submitting this acceptance letter.
4. I / We hereby unconditionally accept the tender conditions of above mentioned tender document(s) / corrigendum(s) in its totality / entirety.
5. I / We do hereby declare that our Firm has not been blacklisted/ debarred/ terminated/ banned by any Govt. Department/Public sector undertaking.
6. I / We certify that all information furnished by our Firm is true & correct and in the event that the information is found to be incorrect/untrue or found violated, then your department/ organisation shall without giving any notice or reason therefore or summarily reject the bid or terminate the contract, without prejudice to any other rights or remedy including the forfeiture of the full said earnest money deposit absolutely.

**Yours Faithfully,**  
**(Signature of the Bidder, with Official Seal)**

**Appendix -2**  
**Certificate for Tender**  
**(To be given on Company Letter Head)**

Date: \_\_\_\_\_

To,

\_\_\_\_\_  
\_\_\_\_\_  
\_\_\_\_\_

Sub: Certificate of compliance as per Rule 144 (xi) GFR's 2017

Tender Reference No: \_\_\_\_\_

Name of Tender / Work: - \_\_\_\_\_

"I have read the clause regarding restrictions on procurement from a bidder of a country which shares a land border with India; I certify that this bidder is not from such a country or, if from such a country, has been registered with the Competent Authority. I hereby certify that this bidder fulfils all requirements in this regard and is eligible to be considered. [Where applicable, evidence of valid registration by the Competent Authority shall be attached.]"

**Yours Faithfully,**  
**(Signature of the Bidder, with Official Seal)**

**Appendix -3**

**Certificate for Tender for Works involving possibility of sub-contracting**  
**(To be given on Company Letter Head)**

Date: \_\_\_\_\_

To,

\_\_\_\_\_  
\_\_\_\_\_  
\_\_\_\_\_

Sub: Certificate of compliance as per Rule 144 (xi) GFR's 2017

Tender Reference No: \_\_\_\_\_

Name of Tender / Work: - \_\_\_\_\_

"I have read the clause regarding restrictions on procurement from a bidder of a country which shares a land border with India and on sub-contracting to contractors from such countries; I certify that this bidder is not from such a country or, if from such a country, has been registered with the Competent Authority and will not sub-contract any work to a contractor from such countries unless such contractor is registered with the Competent Authority. I hereby certify that this bidder fulfills all requirements in this regard and is eligible to be considered. [Where applicable, evidence of valid registration by the Competent Authority shall be attached.]"

**Yours Faithfully,**  
**(Signature of the Bidder, with Official Seal)**

**Appendix – 4**

**Declaration for Local Content**

**(To be given on Company Letter Head - For tender value below Rs.10 Crores)**

**(To be given by Statutory Auditor/Cost Auditor/Cost Accountant/CA for tender value above Rs.10 Crores)**

Date:

\_\_\_\_\_  
To,  
The Director,  
Indian Institute of Technology Kanpur,  
GT Road, Kalyanpur, Kanpur -208016

Sub: Declaration of Local content

Tender Reference No: \_\_\_\_\_

Name of Tender / Work: - \_\_\_\_\_

1. Country of Origin of Goods being offered: \_\_\_\_\_
2. We hereby declare that items offered has \_\_\_\_% local content.

“*Local Content*” means the amount of value added in India which shall, be the total value of the item being offered minus the value of the imported content in the item (including all customs duties) as a proportion of the total value, in percent.

“*\*False declaration will be in breach of Code of Integrity under Rule 175(1)(i)(h) of the General Financial Rules for which a bidder or its successors can be debarred for up to two years as per Rule 151 (iii) of the General Financial Rules along with such other actions as may be permissible under law.*”

**Yours Faithfully,**  
**(Signature of the Bidder, with Official Seal)**